

KASHIN-BECK DISEASE: EVALUATION OF MINERAL INTAKE IN YOUNG TIBETAN CHILDREN FROM ENDEMIC AREAS

MICHAËL DERMIENCE

**TRAVAIL DE FIN D'ÉTUDES PRÉSENTÉ EN VUE DE L'OBTENTION DU DIPLÔME DE
MASTER BIOINGÉNIEUR EN CHIMIE ET BIO-INDUSTRIES**

ANNÉE ACADÉMIQUE 2009-2010

(CO)-PROMOTEUR(S) : GEORGES LOGNAY, FRANÇOISE MATHIEU

© Toute reproduction du présent document, par quelque procédé que ce soit, ne peut être réalisée qu'avec l'autorisation de l'auteur et du doyen de Gembloux Agro-Bio Tech.

Le présent document n'engage que son auteur.

KASHIN-BECK DISEASE: EVALUATION OF MINERAL INTAKE IN YOUNG TIBETAN CHILDREN FROM ENDEMIC AREAS

MICHAËL DERMIENCE

**TRAVAIL DE FIN D'ÉTUDES PRÉSENTÉ EN VUE DE L'OBTENTION DU DIPLÔME DE
MASTER BIOINGÉNIEUR EN CHIMIE ET BIO-INDUSTRIES**

ANNÉE ACADÉMIQUE 2009-2010

(CO)-PROMOTEUR(S) : GEORGES LOGNAY, FRANÇOISE MATHIEU

Acknowledgements

I want to thank the following persons who gave me the opportunity to carry out this work:

Pr. Georges Lognay

for his supervision and his continuous support along this work

Ph.D. Françoise Mathieu

for her devotion to fight this disease, this work would not have been possible without her

William Claus and the KBD fund asbl-vzw

for their financial support

Pr. Jean-Paul Barthélémy

for his supervision and his guidance

Ir. Philippe Maesen of the *BEAGx*

for his collaboration in this project and his precious advices

The members of the *BEAGx* and especially Laurent Lessire

for their patience and their technical assistance

M.D. Rapten Sheero, M.D. Dawa Yundan and the Tibet Center for Disease Control and Prevention

for their collaboration

The KBD fund team in Tibet Autonomous Region: Yangzom, Tselha, Rizen, Lakpa, the two Pema, Rinchen, Dikki, Nima and Tsewang

for their cordial welcome and their field assistance

The members of the analytical chemistry unit

for the good working atmosphere in the unit

Ph.D. Jean-Michel Romnee of *CRA-W*

for his kind collaboration

Pr. Philippe Goyens, M.D. Shancy Rooze and Ms. Martine Robert of the *Queen Fabiola Children's University Hospital (ULB)*

for their collaboration and the time they devoted to me

The Tibetan families implicated in this work

for their welcome and their spontaneous participation

My family and my friends

for their support and their encouragements.

Abstract: Kashin-Beck disease is an endemic and chronic osteochondropathy. This disease principally occurs in the Tibet Autonomous Region and in several provinces of the People's Republic of China. Although many studies have already been conducted and many others are still underway, its etiology remains unknown. A multifactorial hypothesis has been proposed: selenium deficiency, high concentration of organic matters in drinking water (fulvic acids) and mycotoxin poisoning by fungi infecting cereals. This original study aimed to measure the mineral contents of the food most often consumed in severe endemic regions and then to evaluate the daily intake of minerals in young Tibetan children from endemic areas. The mineral elements were selected in relation to their implications in bone metabolism. A sampling campaign split up into two time periods (winter and spring) was carried out. Ten families from two distinct regions were selected based on three criteria: they live in endemic areas; they include a 3 to 5 year-old child; this child has a KBD brother or sister. At the same time, a nutritional survey was made by the means of a prospective questionnaire in order to list the 24h food intake of the 3 to 5 year-old child. This survey highlighted the extremely monotonous cereal-based Tibetan diet. An analytical method for the minerals was developed as follows: mineralization of samples performed by microwave-assisted wet process; mineralized solutions measured by several atomic absorption or emission spectrometric methods and molecular absorption spectrometric methods. The analytical method was validated by mean of certified reference materials. Mean food contents were calculated and compared to food composition reference tables. High iron contents and selenium deficiencies were highlighted in several foods. Daily intakes were estimated combining mineral measurements and nutritional survey results. These were compared to dietary reference intakes from reference tables. This estimation reveals some crucial points: we confirm a marked deficiency in calcium; Ca/P ratios are always low; iron and copper intakes are excessive; zinc is the most probably deficient; while selenium could be deficient; manganese intakes often exceed toxicity thresholds. Nevertheless, this study encounters some limits. The bioavailability of minerals is a critical point that deserves further investigations. Moreover, a larger study over a longer term covering both endemic and non-endemic regions is required for definite conclusions to be reached.

Résumé: La maladie de Kashin-Beck se traduit par une ostéochondropathie endémique et chronique. Cette maladie se rencontre principalement dans la Région Autonome du Tibet et dans plusieurs provinces de la République Populaire de Chine. Bien qu'ayant fait et faisant toujours l'objet de nombreuses études, l'étiologie de cette maladie demeure inconnue. Une hypothèse multifactorielle est cependant formulée impliquant : une carence en sélénium, une forte concentration en acides organiques (notamment acides fulviques) dans l'eau de consommation et un empoisonnement par des mycotoxines dû à une contamination des céréales par des moisissures. Cette étude originale avait pour objet l'analyse des teneurs en minéraux des principaux aliments consommés dans des zones de haute prévalence de la maladie et l'évaluation des apports journaliers en minéraux chez les jeunes enfants susceptibles de déclarer la maladie. Les minéraux étudiés ont été choisis en fonction de leurs implications dans le métabolisme des tissus osseux. Une campagne de prélèvement répartie sur deux périodes (hiver et printemps) a été organisée. Un échantillonnage de 10 familles réparties dans deux régions a été réalisé selon trois critères de sélection : les régions devaient être endémiques ; la famille devait comprendre un enfant âgé de trois à cinq ans ; cet enfant devait avoir un frère ou une sœur atteint de la maladie. Parallèlement à cela, une enquête nutritionnelle a été menée au moyen d'un questionnaire alimentaire prospectif dans le but d'établir la consommation alimentaire sur 24h de l'enfant âgé de trois à cinq ans. Cette étude met en évidence le caractère très monotone de l'alimentation tibétaine, essentiellement basée sur les produits céréaliers. La méthode analytique de dosage des éléments fut la suivante : les échantillons ont subi une minéralisation par voie humide assistée par micro-ondes ; les solutions minéralisées ont été dosées par plusieurs méthodes spectrométriques d'absorption et d'émission atomique ainsi que d'absorption moléculaire. La méthode analytique (minéralisation + dosage) a été validée par une analyse de matériaux de référence certifiés ayant subi la même procédure. Les teneurs moyennes en éléments des différents aliments ont été calculées et comparées à des tables de composition des aliments. Des teneurs excessives en fer et une carence marquée en sélénium ont été constatées dans plusieurs aliments. Les apports quotidiens ont ensuite été estimés en combinant les résultats des analyses minérales et de l'enquête nutritionnelle. Ceux-ci ont été comparés aux apports alimentaires recommandés provenant de tables de référence. Les résultats de cette étude confirment certaines suppositions émises et suggèrent des pistes intéressantes quant aux carences et excès rencontrés : le déficit en calcium est très nettement marqué ; les rapports Ca/P sont beaucoup trop faibles ; les apports en fer et en cuivre sont excessifs ; une carence en zinc est fort probable tandis que celle en sélénium est vraisemblable ; l'ingestion de manganèse dépasse souvent les seuils de toxicités. Néanmoins ce travail présente certaines limites et une étude plus complète permettrait de compléter ces résultats. Notamment une étude abordant la biodisponibilité des minéraux dans l'alimentation tibétaine et portant sur des régions endémiques et non-endémiques serait nécessaire pour arriver à des conclusions plus probantes.

Table of contents

List of tables

List of figures

List of abbreviations

I. Introduction

1	Objectives.....	1
2	Tibet Autonomous Region, People's Republic of China.....	2
3	Kashin-Beck disease	4
3.1	Introduction	4
3.2	Clinical description and diagnosis.....	4
3.2.1	Physiological features and symptoms	4
3.2.2	Diagnosis.....	6
3.3	Ethiology	8
3.3.1	The selenium deficiency hypothesis	8
3.3.2	The high concentration of organic matters in drinking water hypothesis	10
3.3.3	The mycotoxin hypothesis	10
3.3.4	A multifactorial hypothesis	11
3.4	Treatment and therapy	12
4	Cartilage and bones tissues	13
4.1	Cartilages.....	13
4.2	Bones tissues.....	13
4.2.1	Generalities.....	13
4.2.2	Osteogenesis.....	14
4.2.3	Bone growth	15
4.2.4	Bone homeostasis	15
5	Trace elements and their roles in relation to bone metabolism.....	17
5.1	Daily references intakes.....	17
5.2	Calcium (Ca, AMU=40).....	18
5.2.1	Generalities.....	18
5.2.2	Calcium roles in bones tissues	20
5.3	Phosphorus (P, AMU=31).....	20

5.4	Magnesium (Mg, AMU=24.3).....	21
5.5	Iron (Fe, AMU=55.9)	22
5.6	Zinc (Zn, 65.4).....	22
5.7	Copper (Cu, AMU=63.6).....	23
5.8	Manganese (Mn, AMU=54.9)	24
5.9	Selenium (Se, AMU=79).....	24
5.10	Nickel (Ni, AMU=58.7).....	26
5.11	Molybdenum (Mo, AMU=95.9)	26
5.12	Sulphur (S, AMU=32.1)	26
5.13	Arsenic (As, AMU=74.9)	26
5.14	Strontium (Sr, AMU=87.6).....	27
5.15	Fluor (F, AMU=19)	27
5.16	Cadmium (Cd, AMU=112.4).....	27
6	Methods used for elements quantification	28
6.1	Atomic Absorption Spectrometry.....	28
6.1.1	Principles	28
6.1.2	Sources of instrumental noise	29
6.1.3	Instrumentation.....	30
6.1.4	Interferences in atomic absorption spectrometry	35
6.2	Atomic emission spectrometry	36
6.2.1	Principles	36
6.2.2	Inductively coupled plasma source (ICP)	36
6.3	Ultraviolet-Visible Molecular Spectrometry	37
6.3.1	Principles	37
 II. Material and methods		
1	Choice of families and sampling	38
2	Nutritional survey.....	39
3	Mineral elements analyses	39
4	Validation of the method.....	45
5	Evaluation of daily intakes	45

III. Results and discussion

1	Choice of families and sampling	46
2	Nutritional survey	47
3	Analyses of foods mineral contents.....	53
3.1	Limits of quantification	53
3.2	Validation of the method	53
3.3	Linearity ranges and calibration curves	56
3.4	Samples analyses and comparisons with reference tables	56
4	Evaluation of daily intakes	63
4.1	Creation of anamnesis, children's menus and edition of food files.....	63
4.2	Calculation by computing of analyzed foods' contribution to daily intake	64

IV. Conclusion and perspectives

.....	75
-------	----

References

Appendix

List of tables

Table 1 Classification of Kashin-Beck disease in 3 clinical stages (Mathieu et al., 2008c).	7
Table 2 Recommended Dietary Allowances (RDAs) and Adequate Intakes (AIs) (West Sutor et al., 2006a; West Sutor et al., 2006b).	17
Table 3 Dietary reference intakes (Martin, 2000).	18
Table 4 Properties of different types of flame (Skoog et al., 2008).	28
Table 5 Technical features for flame-AAS analyses.	41
Table 6 Technical features for flame-AAS analyses.	41
Table 7 Technical features for hydride generation method and cold vapour method.	42
Table 8 Technical features for graphite furnace ETAAS analyses.....	42
Table 9 Furnace programs for ETAAS analyses.	43
Table 10 Dry matters (%) of foods and comparison with reference tables.	46
Table 11 Dry matters (%) of foods and certified reference materials and comparison with reference tables.	47
Table 12 Food intakes of child number 1_49.	48
Table 13 Food intakes of child number 2_45.	48
Table 14 Food intakes of child number 3_66.	49
Table 15 Food intakes of child number 4_2.	49
Table 16 Food intakes of child number 5_22.	50
Table 17 Food intakes of child number 6_746.	50
Table 18 Food intakes of child number 7_568.	51
Table 19 Food intakes of child number 8_860.	51
Table 20 Food intakes of child number 9_636.	52
Table 21 Food intakes of child number 10_703.	52
Table 22 Limits of quantification in mg/kg of dry matter by element and by period of analysis, n=8.	53
Table 23 Comparison of measurement results with certified values.	54
Table 24 Relative standard deviation by element, expressed in percentage, n=5.	55
Table 25 Linearity ranges of measured elements.	56
Table 26 Mineral contents of barley flour and comparison with reference tables.	58
Table 27 Mineral contents of wheat flour and comparison with reference tables.	59
Table 28 Mineral contents of potato and comparison with reference tables.	59
Table 29 Mineral contents of rice and comparison with reference tables.	60
Table 30 Mineral contents of Chinese cabbage and comparison with reference tables.	60
Table 31 Mineral contents of yak butter and comparison with reference tables.	61
Table 32 Mineral contents of black tea and comparison with reference tables.	61
Table 33 Mineral contents of brewed black tea and comparison with reference tables.	62
Table 34 Recipes expressed for 100g of most common dishes of the survey.	64
Table 35 Phytate content (mg/100g) of some Korean foods (Joung et al., 2004).	67

List of figures

Figure 1 KBD prevalence map of TAR (2009).	1
Figure 2 Soil selenium deficiency in P.R. China (Li et al., 2009).....	1
Figure 3 Distribution of Kashin-Beck disease in P.R. China (Li et al., 2009).	1
Figure 4 Model structure of humic acid (Fulcrum Health Ltd.).....	8
Figure 5 Model structure of fulvic acid (Fulcrum Health Ltd.).....	8
Figure 6 Structure of a typical long bone (Heiserman).	9
Figure 7 Schema of endochondrale ossification (Marieb, 2005).....	13
Figure 8 Energy levels of an electron (Cronk).	15
Figure 9 Example of spectra (Yost and al.).	15
Figure 10 Illustration of the Lambert-Beer's law (Wikipedia).....	15
Figure 11 General diagram of an atomic absorption spectrometer (Wikipedia).	28
Figure 12 Schema of the 3 regions in a flame. Figure 13 Examples of flame absorption profiles.....	30
Figure 14 A laminar-flow burner. (Skoog et al., 2008).....	30
Figure 15 a) Internal view of graphite tube; b) THGA graphite furnace (Perkin-Elmer Life and analytical Sciences, Shelton, CT.).....	30
Figure 16 Schematic of a hollow-cathode lamp.	31
Figure 17 Schematic of an electrodeless discharge lamp.	31
Figure 18 Schematic of an interference filter (University Of California).	32
Figure 19 Czerny-Turner grating monochromator. A: incident beam; B: entrance slit; C-E: concave mirrors; D: reflection grating; F: exit slit; G: outgoing beam (Wikipedia).	32
Figure 20 Schematic of a typical barrier-layer photovoltaic cell.	33
Figure 21 Schematic of a vacuum phototube.	33
Figure 22. Cross sectional schematic of a photomultiplier tube.....	33
Figure 23. Schematic of a silicon photodiode transducer (Kuphaldt, 2002).	34
Figure 24. Schematic of an electrothermal atomic absorption instrument that provides a background correction based on the Zeeman effect (Skoog et al., 2008).	34

List of abbreviations

AA-BG	Atomic absorption minus background correction
AAS	Atomic absorption spectrometry
AES	Atomic emission spectroscopy
AMU	Atomic Mass Unit
ANC	Apports nutritionnels conseillés
bFGF	Basic fibroblast growth factor
BMC	Bone mineral content
BMD	Bone mineral density
BMP	Bone morphogenetic protein
BUT	Butenolide
<i>CDC</i>	<i>Tibet Center for Disease Control and Prevention</i>
Co.Vap.	Cold vapour generation
CRA-W	Walloon Agricultural Research Centre
CRM	Certified reference materials
DCP	Direct current argon plasma
DNA	Deoxyribonucleic Acid
DRIs	Dietary reference intakes
EDLs	Electrodeless discharge lamps
ESCAP	Economic and Social Commission for Asia and the Pacific
ETAAS	Electro thermal atomic absorption spectroscopy
FAAS	Flame atomic absorption spectroscopy
FM	Fresh matter
GD	Glow-discharge plasma
GH	Growth hormone
GSHPx	Glutathione peroxidases

HG	Hydride generation method
ICP	Inductively coupled plasma
KBD	Kashin-Beck Disease
LOQ	Limits of quantification
MIP	Microwave-induced argon plasma
NO	Nitric oxide
PTHrP	Parathyroid-hormone-related peptide or protein
PTH	Parathyroid-hormone
RDA	Recommended dietary allowances
RNA	Ribonucleic Acid
Se-Met	Selenomethionine
Se-Cyst	Selenocystein
T.A.R	Tibet Autonomous Region
USDA	United States Department of Agriculture

I. Introduction

1 Objectives

The main objective of this work was to measure the mineral content of most consumed Tibetan foods. It constitutes an original work in the study of the Kashin-Beck disease (KBD) ethiology. Indeed, previous nutritional studies were based on foods composition reference tables.

For this purpose, a sampling campaign split up into two periods (January and May) was envisaged. We wanted to select ten families from two distinct areas according to several criteria: families have to live in endemic areas and they have to include a 3 to 5 years old child having a KBD brother or sister.

We aimed to develop a food sample procedure which matches with field conditions. Tibetan diet is really monotonous. Eight different foods among the most eaten were intended to sample: barley flour, wheat flour, rice, potato, black tea (as leaves), yak butter, Chinese cabbage and instant noodles. The first step in sample process (dry matters) was planned in the *Tibet Center for Disease Control and Prevention* premises (CDC, Dir.: M.D. R. Sheero).

Another objective was to establish and validate an analytical method of measurement. Samples process (mineralization) was planned in *Gembloux Agro Bio Tech* in the *unit of Analytical Chemistry* (Head of Unit: Ph.D. G. Lognay).

Around ten mineral elements were selected based on their implication in bone metabolism. Analytical measurements were planned in the *Bureau Environnement et Analyse de Gembloux* (BEAGx, Dir.: Ir. Ph. Maesen).

The validation of the analytical method was considered by the mean of certified reference materials in order to ensure the accuracy of analyses. Study of repeatability was also envisaged.

It was also deliberated to compare the measured food contents with food reference tables.

In order to highlight excess or deficiency among the children involved in this study, we envisaged to estimate mineral daily intakes by the mean of a nutritional program called Kidmenu[®]. Thus, a nutritional survey has been developed in order to list the children 24h food intake. Prospective questionnaires have been mentioned. We also planned to establish standard dishes by the mean of a previous nutritional study (de Voghel, 2008) This estimation was planned at the *Queen Fabiola Children's University Hospital (ULB), Dietetics area* (Chief Dietician: Martine Robert, Head of clinic: Pr. Ph. Goyens).

Finally, we intended to highlight conclusions about the mineral nutrition within the limitations of this work.

Organization chart

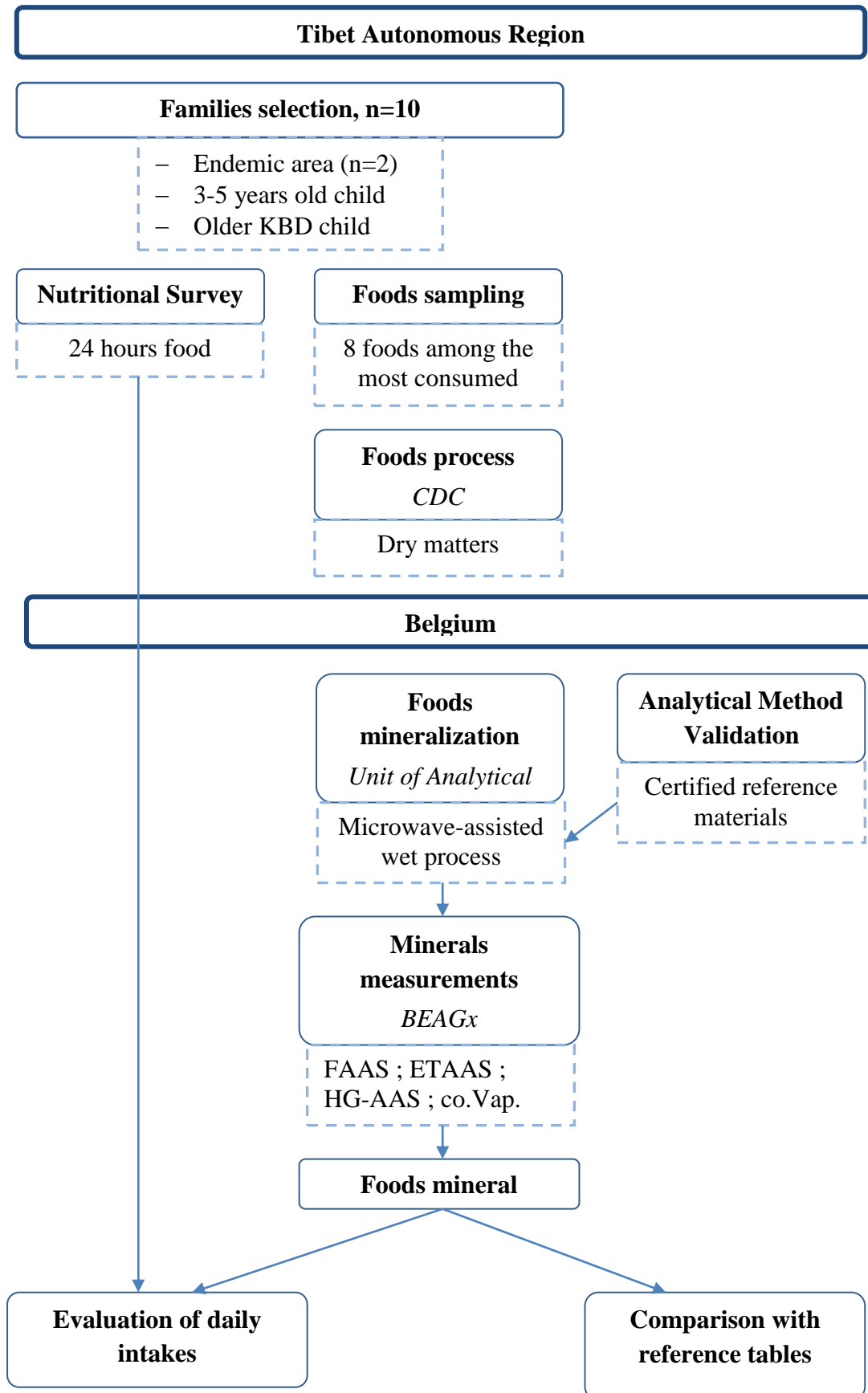

2 Tibet Autonomous Region, People's Republic of China

Tibet Autonomous Region (T.A.R) is located in the South-Western border area of People's Republic of China. Its frontiers are in the North: Uyghur Autonomous Region and Qinghai province, in the East: Sichuan province, from the West to the South-East: India, Nepal, Bhutan, Sikkim, Myanmar and Yunnan province. T.A.R is divided into seven prefectures called Ngari, Nakchu, Shigatse, Lhasa, Lhoka, Nyingtri and Chamdo. (Malaisse and al., 2008a)

Following demographic information is based on the statistics at the end of 2000 from the United Nation Economic and Social Commission for Asia and the Pacific (UNESCAP).

T.A.R. is about 1,228,400 square kilometres, and over 2.62 million peoples. But the main part of the population (80%) lives in the South-East, along valleys of four rivers (Brahmaputra River, Lancang River, Lijiang River and Yangtze River).

The physiomy is diversified, with mountains, desert, grassland and forests. Numerous rivers have their sources in Tibetan Plateau, such as Yangtze, Yellow River, Brahmaputra, Ganges, etc. Those lakes and rivers produce about a third of the country's electricity output. There is also a considerable solar and wind potential energy. Tibet has a large quantity of plants, animals and minerals resources. Additionally, T.A.R. is also potentially rich in tourism resources.

Farming and animal husbandry are the major agricultural activities in Tibet, but productivity is very low, and manual farming and animal husbandry are still the primary pattern. Near urban centres, modern agricultural practices begin to appear, but generally, manpower and animal power are still applied in ploughing the land.

More or less half of the population work as employees, with an average yearly wage of 14,976 Yuan per capita. The annual per capita disposable income of urban residents was 6,448 Yuan, while the annual per capita net income of rural residents is 1,331 Yuan.

Educational level in T.A.R is quite low and a lot of people are still illiterates and semi-illiterates. At the end of 2000, Tibet has four universities, about 110 secondary schools and 842 primary schools.

The sex ratio of the total population is about 102.62 women per 100 men. And the population pyramid is the one of a typical third world country, with a large number of people in the young ages. The crude birth rate (CBR) is 17.6 per 1,000 and the natural growth rate (NGR) is 11.00 per 1000.

According to Haubruge and al., 2000 and Malaisse and al., 2008b, populations share out four macro-ecosystems:

- The urban zone;
- The suburban zone which is mechanized and has communication media;
- The agricultural zone with subsistence farming;
- The pastoral zone over 4500 m with nomads and yaks

The Kashin-Beck disease is only encountered in the agricultural group. A major difference existing between this group and the others is the diet.

In the agricultural zone, food habits consist essentially in butter tea, chang, tsampa, momos and soups or cooking pots. Butter tea is the national drink in south central Tibet, even if it's going to be replaced by sweat tea in urban zones. It is made of brewed black tea, salt and butter (from yak or cow principally). Chang is a local made alcohol obtained from fermented barley. Tibetans (even children) drink great amounts of butter tea and chang. Tsampa is made of barley flour and brewed black tea, salt or butter could be added. Momo is a Tibetan specialty. It is a kind of ravioli made of flour and filled with vegetable or meat. Traditionally it is steamed but nowadays it is sometimes fried. Soups or cooking pots often constitute a meal alone. They are generally consumed at suppertime. Staple food of cooking pot (except water) is the wheat or barley flour (raw or under the form of noodles). It is accompanied with meat and local vegetables (radishes, turnips or edible wild herbs). (Chasseur and al., 2008b)

Urban and suburban food habits are broadly diversified thanks to products coming from other Chinese provinces (foods and agricultural practices such as green houses).

Nomads' diet is principally based on meat and dairy products. Barter is also practiced between nomad and farmers. They barter salt (from salt lakes in the north) or stocker in exchange of barley or wheat (Wangla, 2010).

KBD prevalence map of TAR

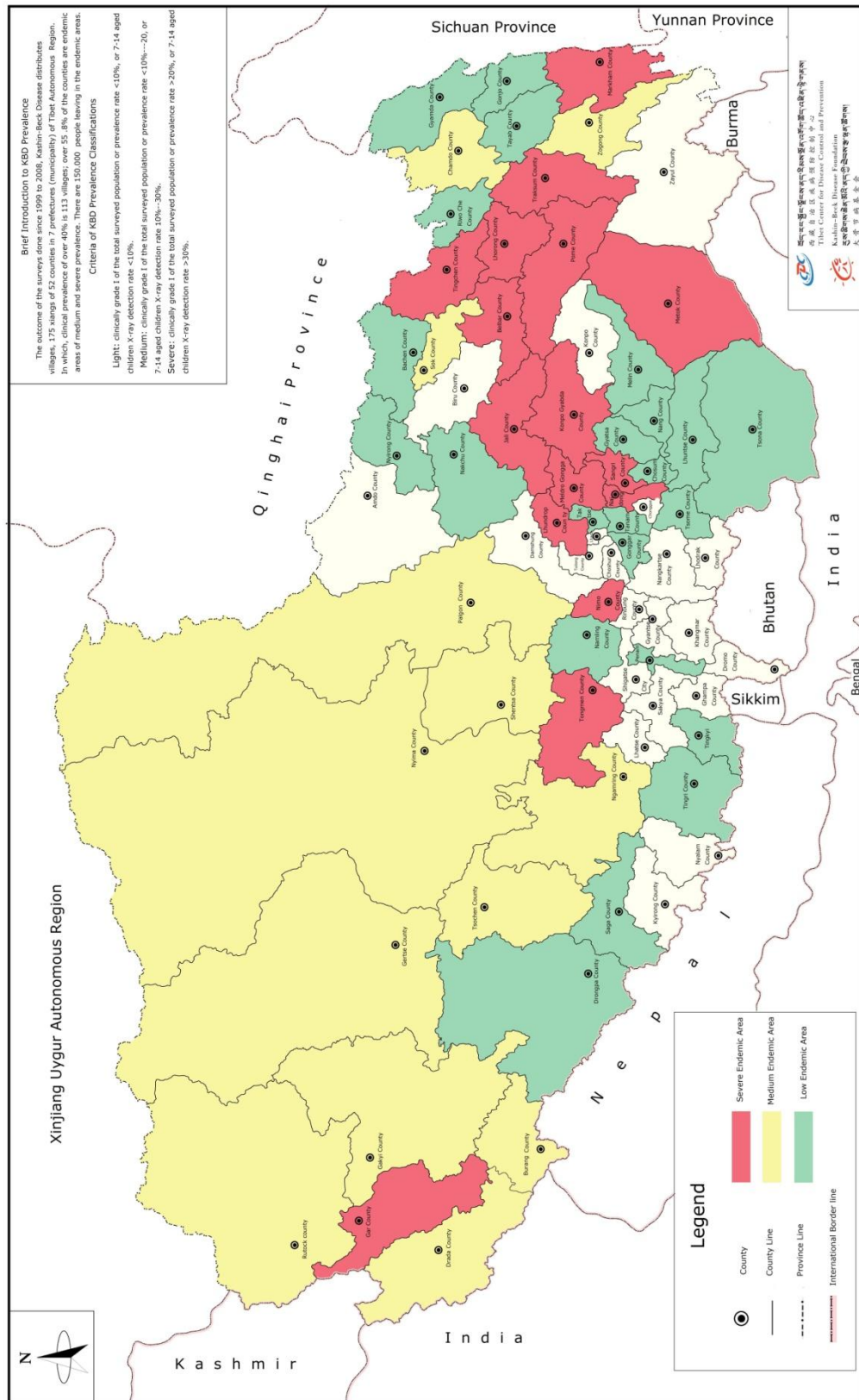

Figure 1 KBD prevalence map of TAR (2009).

3 Kashin-Beck disease

3.1 Introduction

Kashin-Beck disease (KBD) is an endemic and chronic osteochondropathy. The etiology is still unknown although several hypotheses have been proposed.

The first who describe this disease in terms of clinical conditions was I.M. Yurenskiy in 1849, in Eastern Russia populations, near Baikal Lake. In 1861, Dr. N.I. Kashin established a distinction between people of small stature having a limp, and those suffering from hypothyroidism. Both pathologies were endemic in the east of Baikal Lake. Around 1900, Dr. E.V. Beck and his wife A.N. Beck made a detailed study of the disease. They called it “Osteoarthritis Deformans Endemica”. The name of Kashin-Beck disease was given after Beck’s results were published in the Russian journal *Russky Vrach* and in the German review *Archiv für Klinische Surgery*.

In 1925, a commission was created to study the disease and in 1931 a research center was opened in Chita in the Baikal Lake region.

In 1919, due to Japanese occupation in North Korea, a chronic polyarthritis of which clinical signs corresponded to those of KBD was observed by T. Okano. This disease was already known by indigenous since 300 years. Later on, other cases were confirmed, even in the north-east of China. Moreover, the disease was observed among Chinese and Koreans from non-endemic region that came to live in endemic region.

Nowadays, some Chinese schools of medicine and some institutes have research units into KBD. The Russian research center in Chita is still working. A conference in Beijing in 1985 extended the interest among the international scientist community. (Mathieu and al., 2008a)

Depending on sources, it is estimated that KBD affects between 0.74 million till more than 2.5 million people in China and other parts of Asia, and there are between 10 million and 30 million people at risk (Wang and al., 2009; Wang and al., 2008; Mathieu et al., 2008a) Some severe prevalence areas present more than 40% people affected by KBD, especially in Tibet Autonomous Region (P.R. China) (Figure 1), with maximum till 96% among children in some communities. Apparently, urban citizens and nomads are not affected by this disease, and the endemic areas are limited to poor, isolated and rural communities.

3.2 Clinical description and diagnosis

3.2.1 Physiological features and symptoms

Kashin-Beck Disease is characterized by short stature and skeletal deformities especially in long bones and joints. Joints become enlarged, stiff and painful. Mobility of limbs become limited and muscles can be atrophied. Peoples suffering from KBD get tired quickly and are weaker. Symptoms appear during childhood (3-5 years) and become progressively worse.

Physiological feature of the Kashin-Beck disease is a focal chondronecrosis of matured chondrocytes in the deep zone of the growth plate cartilage and the articular cartilage. Necrosis, apoptosis, dedifferentiation of chondrocytes and abnormal expressions of collagen types I, II, III, VI and X in articular cartilage are also observed (Wang et al., 2009). The expression of some cellular regulation factors is also perturbed in articular cartilage, among which:

- Bcl-2: an anti-apoptotic factor which interact with the C cytochrome (Coqueret).
- TGF- β : the transforming growth factor beta is anti-proliferative factors that also control cellular differentiation (Pradayrol, 1999).
- bFGF: basic fibroblast growth factor is involved in the process of wound healing and tissue repair (Anaspec). In the bone microenvironment, bFGF seems to enhance cell motility and invasion of Ewing's sarcoma family of tumors (Kamura and al., 2010).
- PTHrP: parathyroid-hormone-related peptide or protein is similar to parathyroid hormone (PTH) but it has a paracrine or autocrine action. It promotes the cartilage formation by stimulating chondrocytes proliferation. A too high level of PTHrP can induce hypercalcemia (Schlüter, 1999).

Moreover, the KBD patients show a higher serum level of nitric oxide (NO) suggesting that the NO pathway could play a role in chondrocytes necrosis (Wang et al., 2008).

Wang et al., 2009, compared the gene expression profiles between normal human's chondrocytes, KBD patient's chondrocytes and osteoarthritis patient's chondrocytes using oligonucleotides microarray. They identified 79 genes for which the level of expression in KBD chondrocytes was different from the one of normal chondrocytes. 55 genes are over expressed and 24 are lower expressed. All these genes were subdivided into several functional categories (metabolism, transcription regulator/factors, growth factors, proteases, apoptosis, etc.). Compared with osteoarthritis patient's chondrocytes, they identified 11 similarly genes over expressed in both diseases and three lower expressed. However, other disturbed genes remain specific for KBD. It suggests that a modification in the genes expression patterns of chondrocytes induces changes in the molecular mechanism and leads to cartilage degeneration. Moreover, during the transition from normal cartilage to KBD lesional cartilage, the gene expression changes before there is any apparent damage. But one question remains, which genes are disturbed by the primary process of the disease and which are disturbed in response of the cartilage degeneration? Besides, further studies are necessary to better evaluate the variability on genetic expression between persons, and its evolution with the age.

Another study of Duan and al., 2010, compared the gene expression profile between primary knee osteoarthritis patients and KBD patients. They observed some differences of expression levels between the two diseases. Some genes were higher expressed and others were lower expressed. Nevertheless, they observed similar patterns between both diseases indicating that some mechanisms such as chondrocyte matrix metabolism, cartilage degeneration and apoptosis induction pathway are involved into cartilage destruction in KBD.

3.2.2 Diagnosis

Three conditions have been defined by the Chinese physicians for establishing a clinical diagnosis of KBD (Mathieu et al., 2008a):

- The patient must live or have lived in an endemic area for longer than six months;
- The principal complaints and symptoms must be those of Kashin-Beck disease;
- The other osteoarthropathies must be excluded.

According to Chinese authors, Clinical diagnosis distinguishes four stages in the evolution of the disease (Mathieu et al., 2008a):

Early stage: fingers extremities present a flexum, fingers are “arched” and produce cracking sounds. Some joints can be painful (knees and ankles).

Stage 1: enlargement of the joints of the fingers and of the other small cracking joints.

Stage 2: shortening of fingers and toes, enlargement of other joints and beginning of muscular atrophy.

Stage 3: enlargement of the large joints, general loss of mobility, shortening of the limbs and reduction of the height and weight.

However, there are some differences between Chinese and Russian classification. The first one considers separately the clinical or the radiological observations, while the second one combines both. Those two ways of classification could lead to false negatives

Mathieu and al., 2008c, have developed a specific anthropometric description to identify patient suffering from KBD. This study was made on two groups, each one divided into two sub-groups:

- A control group of men and a control group of women, living in a non-endemic region;
- A group of KBD men and a group of KBD women living in an endemic region.

Several quantitative and qualitative parameters have been measured and evaluated, like the height, joints diameter, pain and mobility, the muscular weakness, etc. Then a two-way analysis of variance enabled to point out the most significant parameters. They are the height and the joint mobility of the different peripheral joints. The great advantage of this method is the simplicity of the diagnosis. Moreover, there is no need to bring expensive and cumbersome materials (radiological, biomechanical, etc).

According to this study, a new classification has been proposed, subdivided in three stages (Table 1).

Table 1 Classification of Kashin-Beck disease in 3 clinical stages (Mathieu et al., 2008c).

Stage	Joint deformities	Joint pain	Degree of mobility	Associated symptoms
1	Yes (no*)	No (yes*)	0	No
2	Yes	Yes/no	1 or 2	No
3	Yes	Yes/no	1 or 2	Yes

* Children under 15 years with persistent joint pain without joint deformities and identified as suffering from KDB.

The accessory clinical symptoms are:

- General fatigue: tiredness when waking up;
- Acute fatigue: fatigue appearing immediately after work or during physical effort;
- Muscular weakness: general feeling of muscular weakness;
- Performance at work: incapacity of carrying out usual work;
- Pes planus;
- Waddling gait;
- Small stature.

Hinsenkamp and al., 2008, have also made a radiological study of the appendicular skeleton of patients suffering from KBD. The objectives of this study were to establish a radiological classification of the disease and to study the relationship with their clinical classification.

Based on the results, the radiological classification can be made:

- Grade 0: no radiological change;
- Grade 1: at least one radiological alteration of the epiphysis or the metaphysis;
- Grade 2: at least one radiological alteration of the metaphysis and the epiphysis without fusion;
- Grade 3: local fusion of the metaphyseal growth plate.

After comparison, the clinical diagnosis is more sensitive (90% of identification vs. 56%) but the radiological screening is more specific.

Wang et al., 2008, have investigated a new method to diagnose KBD patients, based on the detection of serum biomarkers using surface-enhanced laser desorption ionization mass spectrometry (SELDI-TOF MS). This study compared the serum proteins profile between KBD patients, controls in KBD areas and non-KBD areas and osteoarthritis controls. They identified three protein peaks significantly differing from controls, corresponding to three proteins with molecular masses of 5336, 6880 and 4155 Da. One peak (5336) matched against type II collagen alpha-1-chain protein. This protein forms fibrils that confers tensile strength and maintain the integrity of articular cartilages. Based upon these peaks, they generated a classification tree able to distinguish KBD patients with a specificity of 88.89% and a sensitivity of 86.36%.

Nevertheless, further investigations are essential to identify definitely the three proteins, and large-scale studies are required to confirm whether this new method can dependably diagnose KBD patients.

3.3 Ethiology

To date, there are three major hypotheses about the ethiology of the Kashin-Beck disease (Wang et al., 2009; Wang et al., 2008; Mathieu et al., 2008a):

- Too low selenium in diet;
- High concentration of organic matters in drinking water (humic and fulvic acids);
- Mycotoxin poisoning by fungi infecting cereals.

It is important to notice that rats have been validated as an experimental model for studies of human bone disorders (Seco and al., 1998).

3.3.1 The selenium deficiency hypothesis

Li and al., 2009, established a close correlation between soil Se concentration and the presence of KBD patients in China (including T.A.R.). In this study, the soil Se concentration was measured by an atomic fluorescence spectrophotometer method in several samples of soil from endemic and non-endemic areas. Distinction was made between natural soils and cultivated soils. They first observed that there is a significant difference of soil Se concentration between humid climate areas and sub-humid climate.

Although no significant difference was highlight, statistical results indicated that natural soil Se concentrations in KBD-affected areas were lower than those in non-affected areas. Moreover, they observed that in average, Tibetan soils have a low Se content compared to Chinese soils. About cultivated soils, the Se concentrations were significantly lower in endemic KBD regions than in non-endemic regions. Moreover, Se concentrations in non-endemic regions were under the Chinese average. For humid areas, the difference between Se concentration in natural soils and in cultivated soils is significant, but not for sub-humid areas. This could be explaining by stronger eluviations by rains and a bigger consumption by plants in humid areas.

Moreover, according to Tan and al., 2002 only a few percentage of this selenium is water-soluble (i.e. bioavailable for plants), between 1.07 and 6.69% depending on the type of soil.

A conclusion of these two studies is that a low soil Se belt crosses over China from southwest (T.A.R) to northeast, and it is related to the prevalence pattern of the Kashin-Beck disease (Figure 2 and Figure 3).

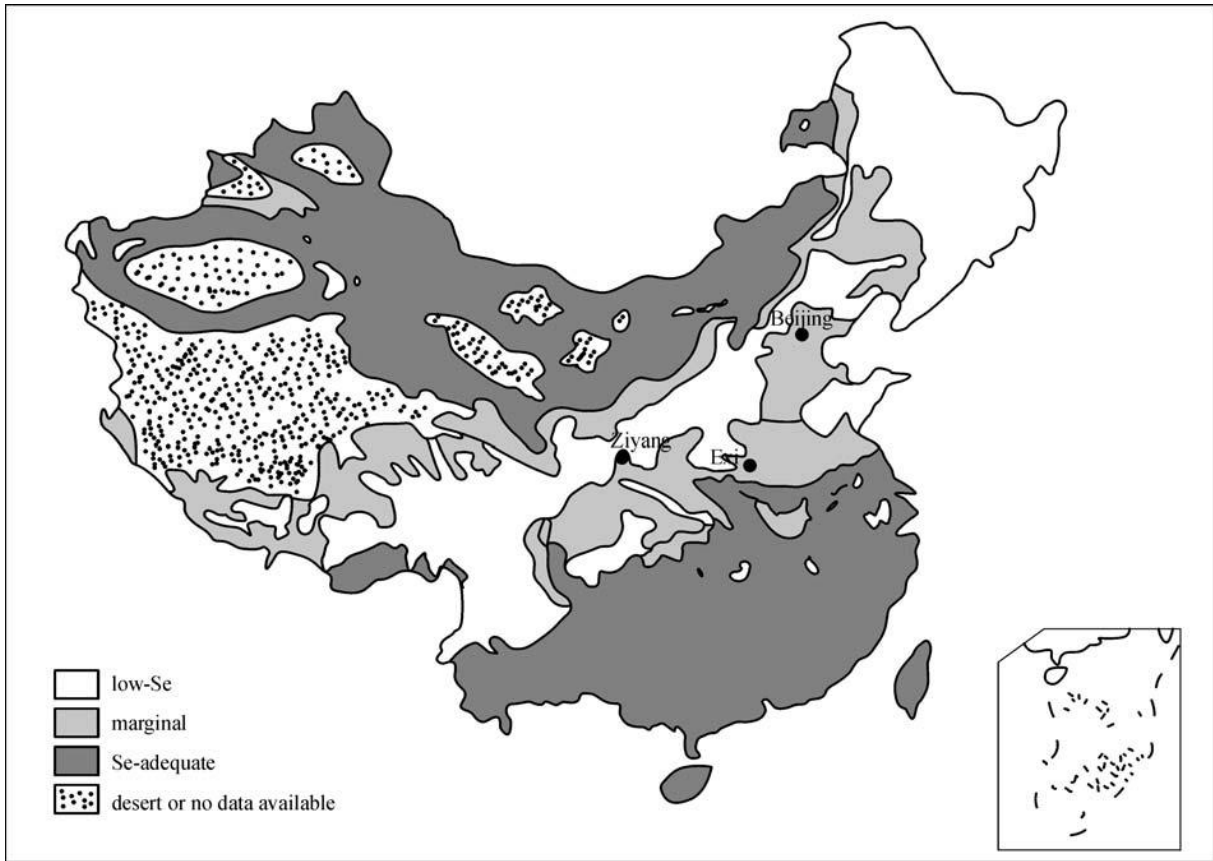

Figure 2 Soil selenium deficiency in P.R. China (Li et al., 2009).

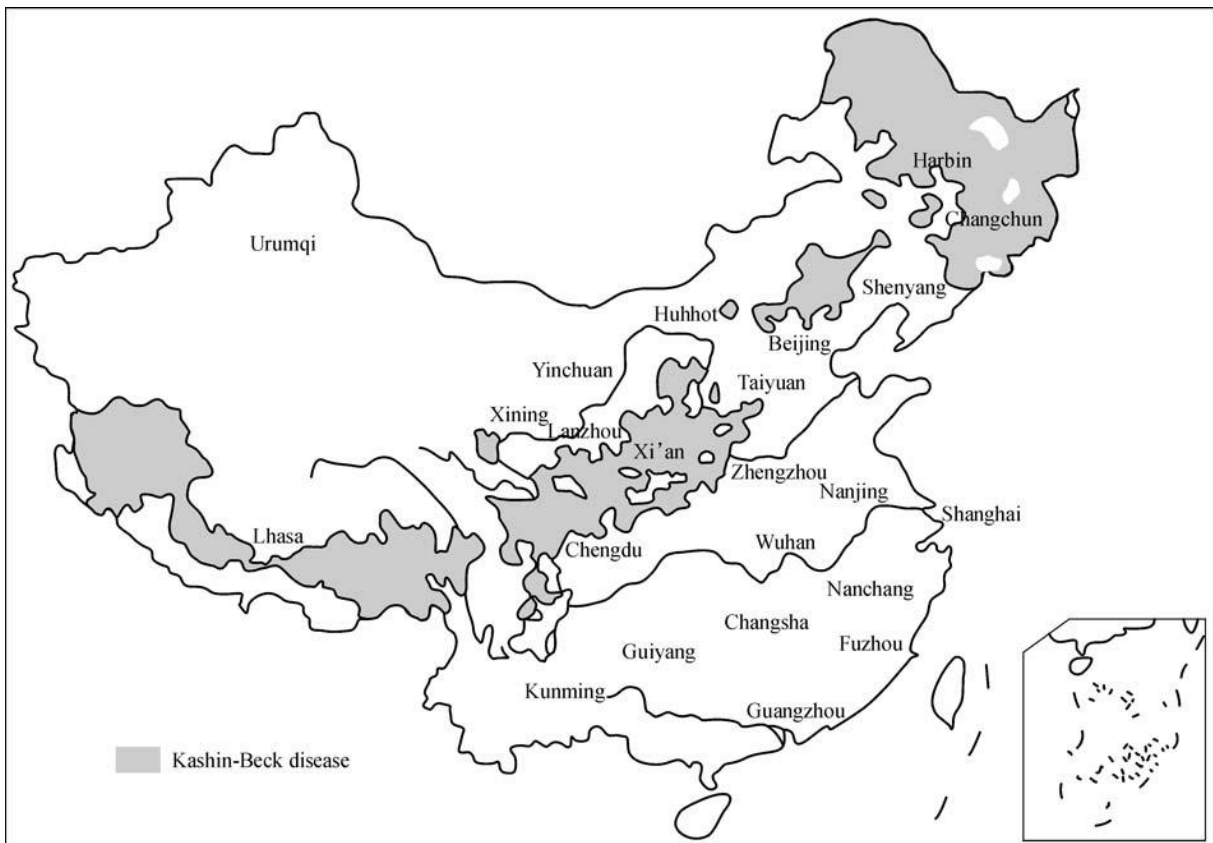

Figure 3 Distribution of Kashin-Beck disease in P.R. China (Li et al., 2009).

Moreno-Reyes and al., 2003, investigated a selenium and iodine supplementation on the Kashin-Beck disease progression. For this randomized controlled trial, three groups of children suffering from KBD aged between 5 and 15 have been made. The control group did not receive anything. The two other groups received iodine in order to make up their deficiency. Later on, one of these groups received 100 μ g Se/d during 11 month and 1mg Se/wk during 12 month in the form of sodium selenate tablets. The other iodine group received placebo tablets. The conclusion of this study is that a selenium supplementation has no effect on established KBD, neither on growth or thyroid function (once iodine level is correct). Nevertheless, one cannot rule out the possibility that selenium deficiency might be part of multifactorial ethiology of KBD.

By contrast, Downey and al., 2009, investigated the effects of a sever selenium deficiency. In mammalian, selenium is found in the form of selenocysteine which is essential for selenoprotein functions. In order to test a selenoprotein deficiency, they used a transgenic mouse line. The *Trsp* gene of this mouse line was deleted in osteochondroprogenitors, inducing a non-incorporation of selenocystein residues into proteins. They used transgenic mice because even with a low selenium diet, one cannot attain the level of deficiency observed in Tibetan children. In fact, it has been noticed that rats maintain their serum Se level at 30 ng/ml when restrain to a poor selenium diet, whereas 90% of Tibetan children are below 27 ng/ml and a third of KBD children are around 5 ng/ml. The mutant mice show severe troubles phenotypically similar to some symptoms of KBD, among which growth retardation, epiphyseal growth plate abnormalities, delayed skeletal ossification and chondronecrosis of articular cartilage. It suggests that high selenium deficiency probably plays a role in the process of Kashin-Beck disease.

Yang and al., 1993, made another study on animal model. They observed the effect of a selenium deficient diet combined with a fulvic acid supplementation in drinking water on two generation of mice. Two groups have been made, one control group fed with normal level of selenium (314 ppb) and normal drinking water. The other group was fed with a poor Se diet (31 ppb) and the drinking water contained 20 ppb of fulvic acid coming from KBD areas drinking water. They sacrificed the 49 days aged mice of the second generation to study their knee joints. It was already established that a selenium deficiency and fulvic acid supplementation could induce modification of collagen I in bone and collagen II in cartilage. But in this study, it has been noticed that mice presented symptoms similar to that in developing osteoarthritis. For example, they developed fibrocartilage at the articular surface of knee joints. They showed a wrong development of the articular space and meniscus, a markedly impaired formation of subchondral bone tissue adjacent to the joint and an early disturbance of differentiation in endochondral ossification. Authors suppose that there is an antagonism between the actions of the fulvic acid in the organism and the consequences of a Se deficiency. In fact, selenium, under the form of selenocystein is essential to the Glutathione peroxidase activity (catalyze the reduction of hydroxyperoxides by glutathione), whereas fulvic acid could induce a production of superoxides via its semiquinone radicals. Thus, the excess of reactive oxygen could lead to an alteration of tissue structure and the extracellular matrix. The same antagonism occurs with humic acid (Peng and al., 1987).

3.3.2 The high concentration of organic matters in drinking water hypothesis

Humic and fulvic acids are included in humic substances. These acids consist in a group of complex polyphenolic molecules having the capacity to chelate with positively charged multivalent ions.

Humic acids and fulvic acids are classified following their solubility. Fulvic acids are soluble and once ingested they have the capacity to accumulate in bone and cartilage. Peng et al., 1987, studied *in vitro* and *in vivo* the damages caused by humic substances on the cartilage cells. They concluded that free radicals are generated by fulvic acids under aerobic conditions. These free radicals hold in oxy- and hydroxyl- functional groups which can induce damage to the chondrocytes' membrane (lipid peroxidation).

Yang et al., 1993 also demonstrated that ingestion of fulvic acid may lead to an impaired transformation of pro-pN-collagen II into collagen II. Moreover, the collagen II molecules present a higher ratio of hydroxyproline/proline which decreases its thermal stability. Both features could interfere with the fibre formation organization. However, further studies are necessary to highlight the exact mechanism of disruption.

La Grange and al., 2001, investigated the relationship between KBD and the drinking water in central Tibet. They rose to two conclusions. The average volume of water container was larger in unaffected families than in KBD families. The organic matter content is higher in endemic regions than in non-endemic.

3.3.3 The mycotoxin hypothesis

Mycotoxins are toxic secondary metabolites produced by fungi. A few fungal taxa are infesting cereals in Chinese KBD endemic areas, among which *Alternaria*, *Trichothecium*, *Drechslera*, *Cladosporium* and *Fusarium*. High rate of contamination is observed due to inadequate cultural practice, storage and high moisture content. The presence of three fungi genera is significantly correlated with the prevalence of KBD (*Alternaria*, *Trichothecium*, *Drechslera*) (Chasseur and al., 1997; Shi and al., 2009). Chasseur and al., 2008a suggest that there are 4 crucial periods of fungal barley contamination in T.A.R. The first period occurs during germination and is due to contaminated seeds by *Drechslera sp.* The second period is taking place in the summer, when grains are on ears. They could be contaminated by *Alternaria sp.*, *Cladosporium sp.* and *Drechslera sp.* The third period happened just after harvest, when barley is kept in bundles on the field before storage. The last one is due to *Alternaria*, *Trichothecium* and *Drechslera* because of wrong storage conditions (insufficient drying in particular).

According to a study on the prevalence of mycotoxins in Kashin-Beck disease (Haubruge and al., 2001), several mycotoxins have been detected in barley (e.g. zearalenone and T2-toxin), but without significantly difference between endemic and non-endemic area. An unknown metabolite has been found both in *Alternaria* extract and in barley coming from KBD families. Complementary investigations on *Alternaria* contaminated barley (2004 Harvest) did not allow to confirm nor the occurrence of mycotoxins, neither the detection of the fore mentioned unknown metabolite (Chasseur et al., 2008a).

Shi et al., 2009, evaluated the cytotoxicity of butenolide (BUT) on chondrocytes. BUT is a mycotoxin produced by *Fusarium sp.*, which is a common mould of cereals in KBD endemic areas. Through this study, they also tried to explain the toxic interaction of BUT with organism. *In vitro* assay revealed that high concentration of BUT (>1 µg/ml) is cytotoxic (decreasing viability, changes in cell morphology) and induces oxidative damages (increasing lipid peroxydation) to chondrocytes. As for fulvic acid, the presence of antioxidants, such as selenium, vitamin C and vitamin E could reduce the butenolide action. So a selenium deficiency has also antagonistic effect together with the presence of butenolide. Suetens and al., 2001, proposed a complementary noxious mechanism for a mycotoxin produced by *Alternaria sp.* This specific mycotoxin could bind to a thyroid hormone receptor in bone cells and lead to disruption of thyroid hormone stimulated bone repair.

Yao and al., 2010, studied the effect of the T-2 toxin (produced by *Fusarium sp.*) combined with low nutrition diet on rat epiphyseal plate growth and development. They made three groups, one control group, one group with normal diet and T-2 toxin and one group with low nutrition diet and T-2 toxin. They observed chondrocytes necrosis in the two T-2 toxin groups but they noticed that combination with low nutrition diet could lead to more serious chondrocytes necrosis in the epiphyseal plate and disturb metaphyseal trabecular bone formation.

3.3.4 A multifactorial hypothesis

In view of the conclusions of these aforementioned studies, it seems that no isolated hypothesis seems able to explain the Kashin-Beck disease. Consequently to the antagonism effects between selenium deficiency and fulvic acids or mycotoxins, one could assume that a multifactorial ethiology is a plausible hypothesis.

Suetens et al., 2001, made an epidemiological study in rural areas in T.A.R. The purpose was to identify the risk factors correlated with Kashin-Beck disease. The study was carried on 575 children among whom 280 were diagnosed clinically as suffering from KBD:

- A strong association of KBD with age and gender is observed. The proportion of KBD children increased with age. And there was a sex ratio in favour of boys.
- A child who has a KBD sibling has higher risk to develop the disease.
- Selenium levels are not correlated with KBD; both healthy and affected persons have low level in endemic areas compare to non-endemic areas. But iodine deficiency was correlated with the disease.
- Families with low incomes (<500 Yuan/year) have more risk to get a KBD children.
- The variety of basic food items and food availability at home was associated to the prevalence of KBD.
- The size of water containers, which was independent of socio-economic status, is linked to the disease and to the fulvic acid concentration. Smaller it was, higher was the fulvic acid concentration, and more it was associated with KBD ($p < 0.001$).
- The storage of grain out of the house was associated with KBD. And the humidity of recently stored grain was higher in KBD families.

- Three fungal genera were independently associated with the disease (*Alternaria*, *Trichotecium* and *Dreschlera*) with an increasing prevalence rate if several taxa are combined.

A multivariate model has been made. It was able to correctly classify 87% of the individuals. This model retains five variables: the gender, the age, the family income, the presence of basic food and the mycological index. The mycological index is a three level index based on the contamination by 0, 1 or 2-3 fungi. The adjusted odds ratio (contribution to the model) varies depending on the level of the index. The higher attributable fraction of this model is held by the mycological contamination, suggesting that mycotoxins hypothesis is one of the most important factors of Kashin-Beck disease in T.A.R.

Shi and al., 2008, said: “As a polygenetic inheritance disease, KBD exhibits obvious familial aggregation and genetic susceptibility accounts for 1/4 of the risk factors for KBD”.

3.4 Treatment and therapy

As long as causes and mechanisms of the Kashin-Beck disease are not known, it is difficult to provide an effective and appropriate treatment. However, Mathieu and al., 2008b, have made a physical therapy study showing that massage, active and passive mobilization and exercises could improve the joint mobility and ease the pain. This physical treatment is more efficient when provided at the earliest stages of the disease (i.e. in the childhood).

Because the results of the previous studies show a correlation between the multifactorial hypothesis and the Kashin-Beck disease, several preventive programmes have been proposed by Chasseur et al., 2008a. For the problem of the fungal contamination a general educational programme and a sanitary programme are suggested. The purpose is to bring farmers into focus on some good agricultural practices such as the importance of the seed dressing and the precautions to take when preparing the biocides, the importance of preparing soils, the importance of the drying and the storage of grains, etc. A food diversification programme is also suggested and carried out notably by the Kashin-Beck Disease Fund asbl-vzw. The idea is to encourage people to eat alternative food whatever wild food (mushroom, pothebs, aromatic herbs, spices) or farming food (build greenhouse to enhance the diversity of vegetables cultivation) in order to get a more varied diet. Another programme carried out by the Kashin-Beck Disease Fund asbl-vzw is targeting the use of nettles which is a common plant in T.A.R. This plant is very interesting because of its accessibility and its nutria, medical and fertilizer properties. (Malaisse and al., 2008c)

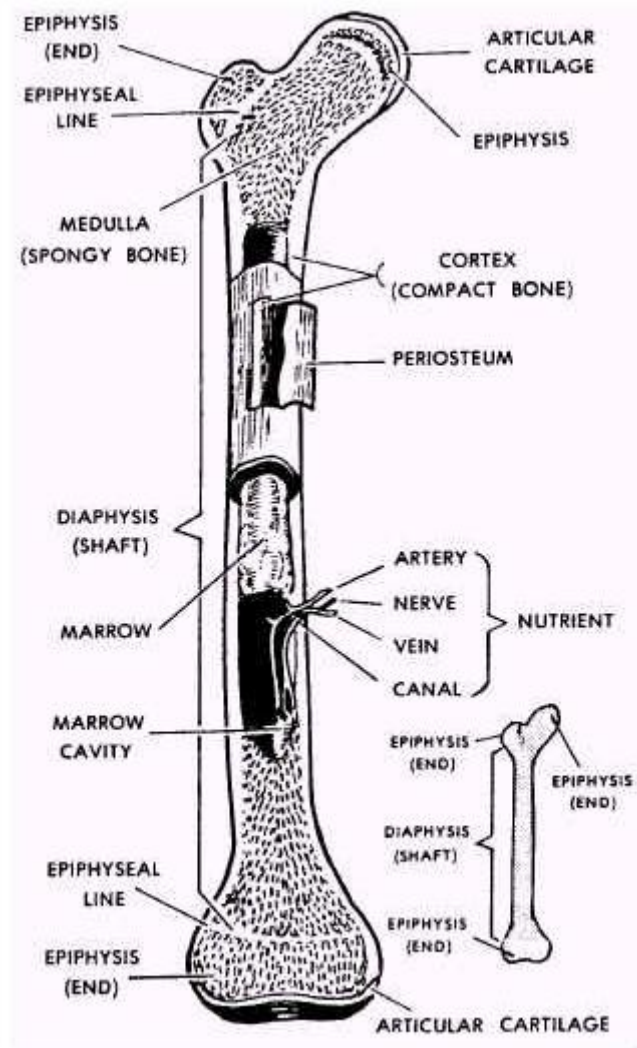

Figure 6 Structure of a typical long bone (Heiserman).

4 Cartilage and bones tissues

4.1 Cartilages

Cartilage is connective tissue made of fibre matrix, chondrocytes and water. It doesn't hold nerve and blood vessel. It is surrounded by the perichondrium, a dense irregular connective tissue which holds blood vessels to supply chondrocytes by diffusion in the matrix.

Chondrocytes are cells which synthesizes cartilage matrix by two different ways: appositional growth and interstitial growth (Marieb, 2005). Cartilage synthesis by chondrocytes is notably under the control of the bone morphogenetic protein (BMP) family, which is also a major regulator of bone metabolism (Tsumaki and al., 2002; Jilka and al., 2007).

There are three main types of cartilages called hyaline cartilage, elastic cartilage and fibrocartilage, which differ in the relative amounts of collagen fibres and elastin fibres. Hyaline cartilage is the most common, made of thin collagen fibres, it is flexible and elastic. Bones articulations are made of hyaline cartilage (except knees articulations, also made of fibrocartilage). (Marieb, 2005)

4.2 Bones tissues

4.2.1 Generalities

Human skeleton is made of 206 bones, separated into two groups: axial and appendicular. The axial skeleton is formed by the skull, the vertebral column and the thoracic cage. The appendicular skeleton is formed by the upper limbs, the lower limbs, the pectoral girdles and the pelvic girdle. (Marieb, 2005)

Bones have several roles (Marieb, 2005):

- Support the body
- Protect vital organs
- Movement, bones are levers for muscles
- Store minerals
- Blood cell production

Bones are full-fledged organs, made of different tissues, with connective tissue, nerves, blood vessels, etc. There are two kinds of bone tissues: compact bone and spongy bone. External layer is constituted by compact bone whereas the inner part is constituted by spongy bone and bone marrow. The structure of a typical long bone is presented in Figure 6. Both extremities are called epiphysis (proximal and distal) and the middle part is called diaphysis. Diaphysis is a compact bone cylinder containing the bone marrow within the medullary cavity. Epiphyses are thicker than diaphysis. They are made of a thin layer of compact bone and the inner part is made of spongy bone. Epiphyses are coated by hyaline cartilage. The junction between diaphysis and epiphysis is called epiphyseal line, which is the remainder of the hyaline cartilage whereby the bone grows. (Marieb, 2005)

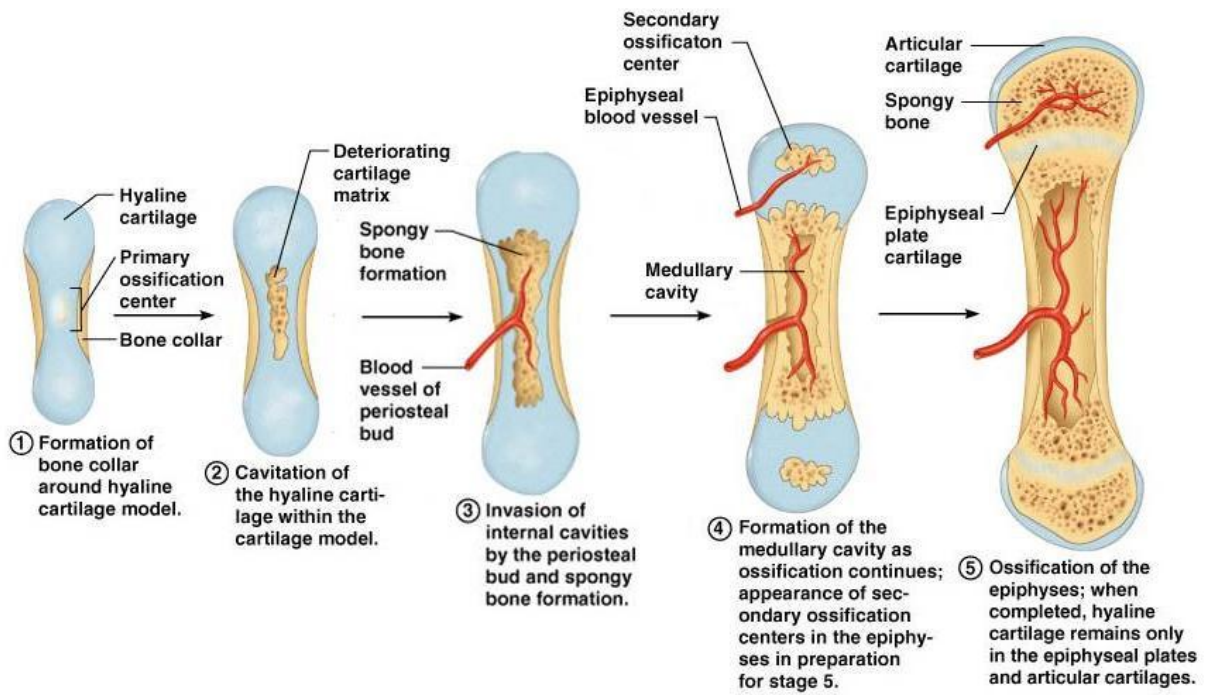

Figure 7 Schema of endochondrale ossification (Marieb, 2005).

Long bones are surrounded by a thin membrane called periosteum (except at articulations). The inner part of periosteum contains large amounts of osteoclasts and osteoblasts. Periosteum is rich in nerve fibres, blood vessels and lymphatic vessels. This membrane is bound to the bone by the Sharpey's fibres. Internal surfaces are covered by a connective tissue called endosteum, containing also osteoblasts and osteoclasts. Osteoblasts synthesize the collagen matrix upon which is bounded blood calcium. Osteoclasts are responsible of the bones lysis. (Marieb, 2005)

Bones contain organic and inorganic constituents. Organic constituents are osteoblasts, osteoclasts, osteocytes, the organic matrix (fibrous proteins, most of which are collagen fibers), globular proteins (osteonectin, osteocalcin) and ground substance (proteoglycans and glycoproteins). Every organic substance is synthesized by osteoblasts. This Organic matrix confers its flexibility and its breaking strength to bones. The inorganic matrix (65% of total weight) is mainly formed of hydroxyl apatite, or tricalcium phosphate ($Ca_{10}(PO_4)_6 \cdot OH_2$). This mineral confers its hardness and its rigidity to bones. Bones also contain small amounts of magnesium, sodium, potassium and some pollutants (heavy metals and radioactive metals). (Marieb, 2005)

4.2.2 Osteogenesis

The process of bones formation is called osteogenesis. It leads to the formation of the embryo's skeleton. During childhood, bones growth in length and in thickness. Osteogenesis starts from fibrous membrane or from hyaline cartilage. It is called respectively intermembranous ossification and endochondral ossification. (Marieb, 2005)

All long bones are formed by endochondral ossification. First the perichondrium, which surround the cartilage, is invaded by blood vessels and transform itself into vascular periosteum. Cells under this periosteum differentiate into osteoblasts, and then osteogenesis can start (Figure 7). (Marieb, 2005)

1. Osteoblasts secrete ossein (proteins constituting the bone organic matrix) forming the bone collar around a hyaline cartilage model.
2. Chondrocytes in the centre of the diaphysis become hypertrophied and deposit a mineralized matrix to form calcified cartilage. It is the primary centre of ossification. Calcified matrix is waterproof for nutrients diffusion, and chondrocytes die and cartilage matrix begins to disintegrate. The rest of the cartilage matrix continues to growth. At the same time, type X collagen gene expression and elevation of alkaline phosphatase activity take place (Shukunami and al., 1997). Vitamin D and protein kinase C play a major role in the growth zone chondrocyte differentiation Sylvia and al., 1998).
3. Periosteal bud invades cavities. This bud consists in artery, lymphatic vessels, nerve fibres, red marrow, osteoblasts and osteoclasts. Cells begin to form spongy bone.
4. Diaphysis gets longer. Osteoclasts form the medullary cavity. Epiphyses, still made of hyaline cartilage, continue to growth.

5. Just before or after birth, secondary centres of ossification appear into epiphyses. Cartilage matrix becomes calcified and begins to disintegrate. A periosteal bud invades cavities and spongy bone is formed. No bone collar is formed around epiphyses and hyaline cartilage remains forming articular cartilage. An epiphyseal plate of hyaline cartilage links epiphyses and diaphysis and allow extension of bones.

4.2.3 Bone growth

After birth, bones lengthen by epiphyses cartilages (articular cartilage and epiphyseal plate) and thicken by periosteum. An affixing growth process is involved. About lengthening, chondrocytes from the epiphyseal plate undergo rapid mitosis and move epiphysis away from diaphysis. Chondrocytes close to diaphysis (older) become hypertrophied, cartilage matrix is calcified, and they die. Cavities are invaded by marrow. Osteoblasts synthesized spongy bone, and osteoclasts extend the medullary cavity. Together with the lengthening, epiphyses extremities are reworked (bone resorption) to keep a good symmetry between epiphyses and diaphysis. Bones lengthening end with the fusion between epiphyses and diaphysis. Bones also thicken and growth in diameter by an affixing growth process. Osteoblasts under periosteum synthesize bone while osteoclasts from the medullary cavity digest it.

Bones growth during childhood is regulated by several hormones. Somatotropin (growth hormone), produced by adenohypophysis, is the major hormone which stimulate epiphyseal cartilage activity. Its production is modulated by thyroid hormones, in order to maintain a good symmetry during the growth. With puberty, sexual hormones (testosterone and oestrogen) induce a rapid growth of bones and a masculation or a feminization of some part of skeleton. At the end of the growth, they also induce the welding of epiphyses and diaphysis. Excess or insufficiency in hormones causes anomalies in skeleton growth. (Marieb, 2005)

4.2.4 Bone homeostasis

Even after growth, bone is a continually reorganizing tissue. One estimates that approximately 10% of the total bone content is replaced per year in human adults (Asagiri and al., 2007). Bone homeostasis is operated at periosteum and endosteum by osteoblasts and osteoclasts. It is regulated by a hormonal process and by mechanical and gravitational strains applied on skeleton (Marieb, 2005). Another regulator of bone remodelling consists in osteocytes apoptosis. Life span of osteoblasts and osteocytes could be modulated by apoptosis. Major factors contribute to apoptosis such as BMP, hormones, immobilization and oxidative stress associated with aging. (Jilka et al., 2007)

Hormonal regulation is made by two antagonistic hormones, parathormone (PTH, parathyroid hormone) and calcitonin. PTH is produced by parathyroid glands and induced by a low blood calcium level. It acts to increase the concentration of Ca^{2+} in the blood by means of bones calcium. Parathormone bonds to osteoblasts membrane receptors. Then, osteoblasts produce factors to stimulate osteoclasts. Stimulated osteoclasts digest bone and release calcium into blood circulation until blood calcium level is enough. Bone resorption is performed by osteoclasts via acidification of extracellular compartment (between osteoclast and bone surface). This acidification is necessary for bone mineral solubilisation and the digestion of organic bone matrix by acid protease. (Rousselle and al., 2002)

Metalloproteinases (family of zinc metalloendopeptidases) have this capacity, among others, to cleave extracellular matrix (Georges and al., 2009).

Calcitonin, produced by C cells of thyroid gland, leads to incorporation of blood calcium in bones tissues and inhibits the bone resorption. The main function of hormonal regulation is to maintain Ca blood serum level rather than preserve skeleton (Marieb, 2005; Fuller and al., 2007).

Bone reaction to mechanical and gravitational strain tends to reinforce bone where it is undergo to strongest strains. Mechanisms by which strains act on bone cells is not well known. Nevertheless, when bone is bended, it produces an electric current which could stimulate bone cells. Moreover, it is known that electric stimulation can help and accelerate the healing of some heavy fractures. (Marieb, 2005)

Perturbations of homeostasis lead to skeleton diseases, especially in the childhood. Osteomalacia, for example, is a group of diseases in which the bone mineralization is insufficient. Osteoid material is produced but no hydroxyl apatite is precipitated. Bones become soft and fragile. Rickets is the equivalent for children, but it's worst because bones are growing up. Moreover, epiphyseal extremities don't stop to growth and never become calcified. Osteomalacia and rickets are generally due to a diet poor in calcium or a lack of vitamin D. Osteoporosis is a group of diseases in which the bone resorption is faster than the bone formation. This is old bone disease. Bones become more and more fragile. Osteoporosis can appear with the decrease of sexual hormones synthesis. In fact, testosterone and estrogen limit osteoclasts activities and promote ossification. Classical treatment for osteoporosis is a complementation in calcium and vitamin D, exercises and hormonotherapy. (Marieb, 2005)

5 Mineral elements and their roles in relation to bone metabolism

5.1 Daily references intakes

Daily reference intakes (DRIs) are summarized in Table 2 and Table 3. They are listed only for the concerned life stage groups investigated in the present study. One is issued from the *Institute of Medicine of the National Academies* (West Suitor and al., 2006a; West Suitor and al., 2006b). The other is issued from the *French agency for food, environmental and occupational health safety* (Martin, 2000).

Table 2 Recommended Dietary Allowances (RDAs) and Adequate Intakes (AIs) (West Suitor et al., 2006a; West Suitor et al., 2006b).

Life Stage Group	P (mg/d)		Ca (mg/d)		Mg (mg/d)		Fe (mg/d)	
	RDA/AI*	UL	RDA/AI*	UL	RDA/AI*	UL	RDA/AI*	UL
1-3 years	460	3000	500*	2 500	80	65	7	40
4-8 years	500	3000	800*	2 500	130	110	10	40
	Zn (mg/d)		Cu (µg/d)		Mn (mg/d)		Se (µg/d)	
	RDA/AI*	UL	RDA/AI*	UL	RDA/AI*	UL	RDA/AI*	UL
1-3 years	3	7	340	1 000	1.2*	2	20	90
4-8 years	5	12	440	3 000	1.5*	3	30	150
	Ni (mg/d)		As (µg/d)		Mo (µg/d)			
	RDA/AI*	UL	RDA/AI*	UL	RDA/AI*	UL		
1-3 years	ND	0.2	ND	ND	17	300		
4-8 years	ND	0.3	ND	ND	22	600		

RDAs are set to meet the needs of almost all individuals in a group. AIs are believed to cover needs of all individuals in the group, but lack of data or uncertainty in the data prevent being able to specify with confidence the percentage of individuals covered by this intake. Number followed by * refer to AIs.

UL = The maximum level of daily nutrient intake that is likely to pose no risk of adverse effects. Unless otherwise specified, the UL represents total intake from food, water, and supplements. The ULs for magnesium represent intake from a pharmacological agent only and do not include intake from food and water.

ND = not determinable.

Table 3 Dietary reference intakes (Martin, 2000).

Life Stage Group	P (mg/d)		Ca (mg/d)		Mg (mg/kg b.w./d)		Fe (mg/d)	
	ANC	UL	ANC	UL	ANC	UL	ANC	UL
1-3 years	360	2500	500	2000	5	350 mg ¹	7	28
4-9 years	520	2500	800	2000	5	350 mg ¹	7	28
	Zn (mg/d) ²		Cu (mg/d)		Mn (mg/d)		Se (µg/d)	
	ANC	UL	ANC	UL	ANC	UL	ANC	UL
1-3 years	8	50	0.75	0.5 ⁴	1-2.5 ⁶	4.2-10	30-40 ⁵	150
4-9 years	11	50	1-1.2 ³	0.5 ⁴	1-2.5 ⁶	4.2-10	30-40 ⁵	150
	Ni (µg/d)		As (µg/d)		Mo (µg/d)			
	ANC	UL	ANC	UL	ANC	UL		
1-3 years	75 ⁶	600	12-25	140-250	30-50 ⁷	350		
4-9 years	75 ⁶	600	12-25	140-250	30-50 ⁷	350		

¹ 350 mg in supplementation to ANC² ANC for an intestinal absorption rate of 20%³ 4-6 years = 1; 7-10 years = 1.2⁴ mg/kg b.w./j⁵ 30 for women and 40 for men (issued from FAO/WHO/IAEA, 1996)⁶ estimated needs for adults⁷ ANC for adults

5.2 Calcium (Ca, AMU=40)

5.2.1 Generalities

This chapter is based on books and works of the following authors: Setrick, 1991; Sarazin and al., 2000; Martin, 2000 ;Marieb, 2005; Médart, 2009.

Calcium is the most important mineral in human body (1-1.2kg). Skeleton contains more than 99% of the inorganic calcium in the form of tricalcium phosphate and hydroxylapatite.

It is absorbed by two different ways:

- One non-regulated and non saturable way, by intercellular spaces of enterocytes of small intestines;
- Second one, regulated, transcellular and saturable, is operated by the duodenal cells.

The active way (second one) is regulated depending on intake and needs. Active transport is achieved by a carrier protein called calbindine-D which binds up calcium. Synthesis of this protein is induced by calcitriol (1,25 dihydroxyvitmineD₃) an active form of vitamin D. Calcitriol could also increase membrane permeability by activating Ca-ATPase. Calcium absorption decrease when 1 α -hydroxylase activity decreases. This enzyme is responsible of the hydroxylation of calcidiol into calcitriol, and its activity decrease with age or with toxic factors (such as cadmium).

The mean real intestinal absorption rate (RAR) of Ca is about 38%, considering a quite low Ca diet of 500 mg/day.

The cells of the renal distal tubule (kidney) are able to reabsorb Ca²⁺ depending on the blood level. This reabsorption is enhanced by calcitriol and PTH.

Just a part of the food calcium content is absorbed, depending of its bioavailability. Plant origin calcium is less available than dairy products and mineral calcium (e.g. CaCO_3). Absorption ratio for dairy products ranges from 25 to 35%. One has to differentiate absorbability and absorption. Indeed, absorbability depends on the food features, while absorption also depends on intestines capacity to absorb. Moreover, some factors affect the calcium absorption, for example: acid pH or lactose ingestion increase the calcium absorption rate, while high phosphate diet decreases this absorption rate. Oxalic acid (from vegetables and black tea) and phytic acid (from cereals) can form insoluble complexes with calcium and decrease absorbability. Furthermore, bioavailability also involves the ability of bone to bind up and to retain calcium. Daily loss of calcium for healthy adults is about 150 mg by urines and about 450 mg by faeces. A salt supplementation in diet increases Ca urinary excretion.

Calcium metabolism is principally regulated by three hormones:

- Parathormone (PTH, parathyroid hormone), produced by parathyroid glands, is induced by a low blood calcium level. It acts to increase the concentration of Ca^{++} in the blood by the means of bone calcium. Parathormone bonds to osteoblasts membrane receptors. Then, osteoblasts produce factors to stimulate osteoclasts.
- Calcitonin, produced by C cells of thyroid gland, leads to incorporation of blood calcium in bones tissues and stops the bone resorption.
- Calcitriol which is issued from hydroxylation of calcidiol into calcitriol by 1α -hydroxylase in kidney. This hormone step in intestinal Ca absorption. It is also involved in Ca homeostasis and bone mineralisation by acting on Ca reabsorption in kidney; by inhibiting synthesis of PTH; by stimulating maturation of osteoclast and controlling differentiation and activities of osteoblasts and chondrocytes.

The main purpose of the hormonal regulation is to maintain the blood calcium level (and not to keep the skeleton in good conditions).

There are some interactions between calcium and different ions:

- A magnesium deficiency induces a higher calcium absorption rate. The optimal Ca/Mg intake ratio is about 2 in order to prevent calcium deposition in muscles or kidneys.
- Too much calcium could decrease iron bioavailability.
- Optimal Ca/P intake ratio is from 1.2 to 1.6. Too high ratio signifies a lack of phosphorus and an excess of vitamin D, it could lead to bone metabolism disturbance. Too low ratio reveals a too high phosphorus diet.
- High values of calcium can disturb manganese metabolism.
- Low value of calcium promotes lead assimilation.
- Cadmium disturb calcium metabolism.
- Sr/Ca ratio decrease with meat proportion in diet.

Calcium steps in bone metabolism, blood clotting, cellular adhesion, nervous impulse transmission, muscular contraction, cell division, etc.

5.2.2 Calcium roles in bones tissues

As seen in 4.2.4, bone is a continually reorganizing tissue. It is a mineralized connective tissue made of three specialized cell types (osteoblasts, osteoclasts and osteocytes), an amorphous substance rich in mucopolysaccharid acids and a collagen matrix linked with hydroxyl apatite (crystalline mineral of tricalcium phosphate). (Marieb, 2005)

Osteoblasts synthesize the collagen matrix upon which is attached blood calcium. Osteoclasts are responsible of the bones lysis. Both activities are regulated by the two aforementioned hormones (PTH and calcitonin). (Marieb, 2005)

Kaji and al., 1996, studied the effects of high extracellular calcium concentration on osteoclast-like cell from mice. They conclude that high $[Ca^{2+}]$ (from 3 to 5 mM) stimulates osteoclast-like cell formation and bone-resorbing activity of mature osteoclasts, probably via osteoblasts.

Children with low dietary calcium intake present a lower bone mineral content (BMC) and bone mineral density (BMD) (Pettifor and al., 1997). A long term calcium deficiency (or vitamin D) leads to insufficient mineralisation of ossein in children (rickets) (Martin, 2000).

5.3 Phosphorus (P, AMU=31)

Deficiency in diet is rare. The phosphorus metabolism is linked to calcium and vitamin D metabolisms. The body content is about 700g of which 85% is bound to Ca and located in bones. It is the second mineral in human body.

The majority of phosphorus is absorbed by passive diffusion. Nevertheless, a small part of phosphorus is actively transported, assisted by calcitriol.

Absorbability of P greatly depends of its origin. It is about 80% for soluble minerals orthophosphates and about 30% for phytates. In a relatively balanced diet, mean real absorption rate is about 70-75% for children and pregnant women and about 65% for adults. Phosphorus is principally eliminated by urines. Total daily loss would be about 300mg.

Excess in phosphorus intake is not toxic but can have impact on calcium metabolism and bone mineralization. On the long run, simultaneously with a calcium deficiency, it could unfavourably modify bone remodelling by acting on PTH regulation.

(Setrick, 1991; Martin, 2000 ; Médart, 2009)

Phosphorus is essential for many enzymatic reactions such as in the oxidative phosphorylation pathway or in the bone mineralization (with alkaline phosphatase). It is also present in phospholipids, components of the cellular membrane. Hexosephosphoric esters, which can be hydrolyzed by alkaline phosphatase, are probably implicated into ossification. (Martland and al., 1926)

Recently it has also been suggested that high extracellular concentration of inorganic phosphates downregulates osteoclastic differentiation and bone resorption activity (Mozar and al., 2008).

Children from South Africa deficient in calcium or with elevated alkaline phosphatase levels have significantly lower BMC, BMD and a trend toward greater BW than normal children (Pettifor et al., 1997).

5.4 Magnesium (Mg, AMU=24.3)

In term of weight, magnesium is the third mineral of the organism. 50% to 70% of the body content is found in bone tissues. The rest is intracellular (an infinitesimal part of magnesium is bounded to plasma proteins). 1.4% of the mineral bone matrix is trimagnesium phosphate.

20% to 50% of ingested magnesium is absorbed by secondary active transport (the uphill movement uses energy from the downhill movement of another molecule) in the terminal ileum. This absorption inhibits the manganese absorption. It is also passively absorbed by transcellular fluids. High fat meal can reduce the magnesium assimilation rate. It is also reabsorbed in kidneys.

Magnesium has an essential role in our organism. More than 300 enzymes required it, such as acid and alkaline phosphatase, ATP-ase, phosphokinases, enzymes of the oxidative phosphorylation pathway, etc. Therefore, magnesium takes place into a lot of metabolic pathways and notably in bone metabolism and chondrogenesis.

A deregulation of magnesium metabolism can be involved in chronic chondrocalcinosis, in myositis ossificans and in extra-skeletal ossification and calcification.

Estimation suggests that about 30% of the population suffer from a lack of magnesium due to a modification of our feeding habits.

(Scrick, 1991; Martin, 2000 ; Médart, 2009)

Some studies suggest that a supplementation in this mineral could enhance the bone formation by acting on the calcium metabolism. Serum Parathormone seems to decrease while calcitonin secretion is enhanced. (Mizoguchi and al., 2005; Sarazin et al., 2000)

On the contrary, a poor magnesium diet on rats induces (Sarazin et al., 2000):

- A decrease of the trabecular bone volume;
- An upregulation of osteoclastic activities without osteoblast activation;
- An hypercalcemia ;
- A reduction of serum Parathormone and vitamin D serum.

Magnesium deficiency could be due to a poor magnesium diet, to hypoabsorption (pathological causes such as kwashiorkor or excess of laxative use), to hyperadrenocorticism (Cushing's syndrome, resulting in endocrine disturbance), to type 2 diabetes or to a too high renal elimination (diuretic or drugs use, alcoholism, etc.). Persisting hypomagnesaemia could induce hypoparathyroidism and disturbance of the vitamin D metabolism. (Sarazin et al., 2000)

5.5 Iron (Fe, AMU=55.9)

Iron is an essential element for the organism and despite its abundance, it seems that a large part of the populations suffer from iron deficiency.

The body content is about 2 to 4 g. Most of the iron is under the form of hemoglobin/myoglobin, but a stock of iron (± 1 g) is located in the liver, the intestinal mucous cells and in the bone marrow. Free Serum iron represents a small amount and is used for transport and mobilization.

Iron losses are weak, about 1 mg a day (2 mg for women during menstruation) by urines, bile and desquamation of intestinal mucous cells. Despite losses, iron needs are low because of its recycling by the organism.

Iron is absorbed by the mucous cells of the duodenum and the first part of the jejunum. It is bounded to ferritin for storage and released as Fe^{3+} or bounded to a transport protein called transferrin. Bioavailability of iron depends on the source. Absorbability of haem iron is greater than bioavailability of nonhaem iron (respectively 25% and less than 10%). Depending on the diet, iron absorption of a given meal varies from 1 to 20%. Nonhaem iron absorption rate decrease with a Zn/Fe ratio upper 8 and a Ca/Fe ratio raising 63. Phytic acid, polyphenols (including tannins) and fibres also diminish this absorption rate. Proteins and some organic acids such as vitamin C and citric acid increase this absorption rate. High consumption of tea (polyphenols) and manganese supply could also reduce iron assimilation.

Iron is involved in reduction-oxidation reactions via enzymes such as cytochromes, catalase, peroxidase, superoxide dismutase, etc. Two of these enzymes are important for the bone formation: the procollagen-proline hydroxylase and the procollagen-lysine hydroxylase.

(Sctrick, 1991; Martin, 2000 ; Médart, 2009)

Normal plasma transferrin concentration seems important for a normal bone mineralization while iron deficiency does not affect in mice (Malecki and al., 2000). But according to Medeiros and al., 2004, rats fed with iron deficiency diet present lower bone mineral density (BMD) and content (BMC).

On the other hand, iron overload inhibits osteoblast activity when bound to ferritin (due to a ferroxidase activity). This inhibition can disturb bone metabolism by a lower calcification and a downregulation of several osteoblasts genes. It results into a decreased mineralization, osteopenia, and osteoporosis (Zarjou and al., 2010). Iron excess, concomitant with vitamin C, can increase oxidative stress due to free radicals (Martin, 2000).

5.6 Zinc (Zn, 65.4)

Zinc is an essential dietary mineral. 30% of the body content is located in bone tissues.

Zinc is absorbed by the duodenum and the ileum. Active transport and storage is assured by metallothionein (which is not specific of zinc). Bioavailability of Zn greatly depends of the type of diet. Its absorption ranges from 35% in a high animal protein diet to less than 15% in a

diet rich in plant products and poor in meat. Phytic acid, principally found in cereals, grains and legumes, interact with calcium and zinc to form insoluble phytates resulting in an inhibited absorption. Fibres have also an inhibiting action. Concerning children, nonhaem iron overload (in a Fe/Zn ration ≥ 2) can also reduce the absorption rate of zinc. A same effect is observed for copper (Cu/Zn ≥ 1) and tin (Sn/Zn ≥ 4). Absorption rate seems also influenced by zincemia.

(Sctrick, 1991; Martin, 2000 ; Médart, 2009)

Zinc daily losses are about 1 or 2 mg. It occurs principally by faeces. A small amount is also ejected by urines, sweat and sperm. Urines losses are higher in osteoporotic individuals (Hadley and al., 2010).

Zinc has only one oxidation state so it doesn't act as electron donor or receptor but as Lewis acid. Zinc is a cofactor of important enzyme involved in bone matrix mineralization such as alkaline phosphatase, collagenase, Type IV gelatinases, carbonic anhydrase II and tartrate-resistant acid phosphatase (Hadley et al., 2010). On top of its physiological impacts in proteins synthesis, zinc plays an antioxidant role. In particular it stabilizes biological membranes and it is a cofactor of Cu-superoxide dismutase (Martin, 2000).

Zinc supplementation significantly increase alkaline phosphatase activity and calcium content in femoral-metaphyseal tissues of newborn rats, resulting in a beneficial effect on bone density (Ma and al., 2000). It also stimulates calcitonin receptor and stops the effect of parathyroid hormone (Moonga and al., 1995; Holloway and al., 1996). Zn adequate level regulates osteoclasts maturation and activity, resulting in a reducing bone resorption. Moreover, it enhances osteoblasts proliferation and differentiation (notably by the means of zinc finger proteins) and bone extracellular matrix mineralization (Kawai and al., 2007; Beak and al., 2007; Hadley et al., 2010). In addition, it seems that endogenous Zn promotes the protein synthesis involved in the bone growth (Ma and al., 2001). Ovesen and al., 2001, even state that zinc could have a similar positive effect on bone that the one of growth hormone (GH) or insulin-like growth factor 1 (IGF-1).

On the other hand, zinc deficiency in growing rats induces a reduction of the bone mass and a decrease of osteoclasts and osteoblasts number (Sarazin et al., 2000). The effect on the bone mass (length, BMC and BMD) is increased when rats are exercised (Seco et al., 1998). Children having a zinc deficiency present a late growing (Martin, 2000). It can also induce an impaired skeletal human growth (Diplock, 1987).

5.7 Copper (Cu, AMU=63.6)

This chapter is based on books and works of the following authors: Sctrick, 1991; Sarazin et al., 2000; Martin, 2000 ; Médart, 2009.

Copper is usually found as bivalent cation (Cu²⁺). This element is present in various foods and its global RAR ranges from 20% to 40%. It is absorbed by active transport in the proximal duodenum. The copper absorption decreases with zinc excess and alcohol consumption. Molybdenum, cadmium and tin also diminish copper bioavailability.

Copper take part in the bone solidity and the cartilage integrity. Indeed, copper is essential to several enzymes, among which some play a vital role in bone metabolism (e.g. lysyl oxidase which is involved in the lysine oxidation that will create peptide bonds between elastin and collagen). Besides, animals with copper deficiency show impairment of secondary bone and cartilage tissues.

Copper has an ambivalent role in oxidative stress. Superoxide dismutase, a metalloenzyme containing Cu, is implicated in free radicals elimination. By contrast, free copper ions can generate free radicals inducing lipid peroxidation (combination of free radicals with electrons from the membrane lipids resulting in damaged cells) and DNA damages.

5.8 Manganese (Mn, AMU=54.9)

This chapter is based on books and works of the following authors: Matsumoto and al., 1991; Sctrick, 1991; Sarazin et al., 2000; Martin, 2000.

Manganese is an essential trace element principally found in nuts and cereals. Tea also contains great amounts of Mn. The body content ranges from 12 to 20 mg. Intestinal absorption is quite low: about 5%. Absorbability could be reduced by phosphates, calcium, iron polyphenols and fibres. Mn deficiency is quite rare for human. Nevertheless, baby infants could suffer from a deficit in manganese due to a low absorption rate. This could be caused by an excess in iron, zinc, chrome or cadmium.

Manganese has several possible valences (from 2 to 7). It is a cofactor of numerous enzymes and it plays more than a few functions in our organism. Most of them are attributable to its reduction-oxidation potential. As well as copper, Mn is also involved in free radicals elimination via superoxide dismutase. It is important for bone metabolism because osteoclasts produce superoxide which inhibit osteoblasts. Particularly, manganese is involved in chondroitin sulphates and proteoglycan synthesis which constitute the fundamental substance of the cartilage. A deficit in manganese could induce ostarthritis with epiphyseal dysplasia and a disrupted mineralization.

5.9 Selenium (Se, AMU=79)

This chapter is based on books and works of the following authors: Diplock, 1987; Matsumoto et al., 1991; Sctrick, 1991; Sarazin et al., 2000; Martin, 2000; Moreno-Reyes and al., 2001; Tapiero and al., 2003; Chwan-Li and al., 2009.

Selenium has a lot of similitudes with sulphur. Although selenium is rarer than sulphur, it sometimes takes the place of this last in proteins which are thus called selenoproteins.

The selenium body content is approximately equal to 13 to 21 mg for adults. About 75% is incorporated into glutathione peroxidase through selenocystein. Absorption and bioavailability of selenium depends of its form but it is generally high (50 to 95%).

Selenomethionine (Se-Met) is the most easily absorbed by the distal small intestine via the Na^+ -dependent neutral amino acid transport system. Soluble salts such as selenate (SeO_4^{2-} , i.e. S^{6+}) or selenites (SeO_3^{2-} , i.e. Se^{4+}) are less absorbed (respectively by active transport and passive diffusion). Phosphorus, fibres and heavy metals decrease the bioavailability of Se.

Plants are one of the main sources of selenium, in which more than 50% is under the form of Se-Met. The rest is under the form of selenocystein (Se-Cys), methyl-Se-Cys, γ -glutamyl-Se-methyl-Cys, selenites and selenates. Cereals, grains and vegetables are usually rich in selenium but it largely depends on the soil concentration and composition, on the rainfall, the climate and the pH.

Higher animals are unable to synthesize Se-Met, unlike selenocystein (Se-Cyst), but they can catabolise Se-Met. Selenium homeostasis is renal regulated and selenium is principally excreted by urines under the form of trimethyl-Se (a small amount of dimethyl-Se is also sending out by breath). It seems that a selenium deficiency increases its absorption and decreases its excretion.

Selenium has an important reduction-oxidation role due to its numerous oxidation levels (-2, 0, +2, +4 and +6) and due to its incorporation into several enzymes as Se-Cyst. More or less half of these enzymes are implicated into antioxidant functions. Main seleno-enzymes are glutathione peroxidases (GSHPx). There are four types of GSHPx. Their main role is to protect cells against free radical damages. One of them principally acts synergistically with tocopherol (vitamin E) to prevent lipid peroxidation.

This action is important because chondrocytes product many oxygen radicals in pre-mineralized cartilage. Osteoclasts also generate superoxide (in order to degrade the bone matrix). In normal condition, osteoblasts synthesize glutathione peroxidase to protect themselves. The apoptosis rates of osteoblasts and osteocytes increase under oxidative stress conditions. The osteoblast differentiation also decreases whereas differentiation and function of osteoclasts increases.

It is clear that a long-term selenium deficiency induces growth retardation and impaired bone metabolism. Rats fed with a selenium deficient diet for two generations show the several features compared to control rats:

- A strongly reduced glutathione peroxidase activity;
- A decrease in plasma selenium concentration;
- A reduction of growth hormone (GH) and insulin-like growth factor I (IGF-1);
- An increase in urinary calcium excretion;
- A double plasma parathyroid hormone (PTH) concentration as well as vitamin D;
- A reduction of weight, length, bone mineral density and bone mineral content.

5.10 Nickel (Ni, AMU=58.7)

This chapter is based on books and works of the following authors: Sctrick, 1991; Martin, 2000.

Our body contains about 10 mg of nickel, distributed in every organ with predominance in bones. More or less 10% of the ingested amounts are actively absorbed by the small intestine.

Nickel is a constituent of superoxide dismutase enzymes. Nickel plays an important role in the carbohydrate metabolism. It is also an essential element to stabilize DNA and RNA. No human deficiency has been observed.

Phytic acid forms with nickel an insoluble coordination complex inhibiting its absorption. A competition exists between Fe, Cu, Zn and Ni for absorption.

5.11 Molybdenum (Mo, AMU=95.9)

Depending on the literature, the absorption rate ranges from 25 to 80% or is close to 90%. The urinary excretion varies from 17 to 80% of the body content. Overload in Mo is very rare but it could decrease the bioavailability of copper. (Sctrick, 1991; Martin, 2000)

Molybdenum is a co-factor of many enzymes involved in reduction-oxidation reactions. The metabolism of Mo seems to be linked to the one of copper and sulphur. (Sctrick, 1991; Martin, 2000)

Too high doses of molybdenum have shown to inhibit the foetal development and the processes of bones ossification in fetuses (Nadeenko and al., 1978; Vyskocil and al., 1999).

5.12 Sulphur (S, AMU=32.1)

Sulphur daily needs are about 850mg. The body content is about 140g. Dietary sulphur is principally supplied under the form of methionine and cysteine (from animal products and *Allium sp.*). Sulphur plays major role in connective tissues such as cartilages (chondroitin sulphates and keratan sulphates). (Sctrick, 1991)

5.13 Arsenic (As, AMU=74.9)

No human deficiency has been observed. Organic As constitutes 80% of daily intake. It is less toxic than mineral As (Martin, 2000). As steps in methionine metabolism and in phosphorylation (and consequently plays a role in bone metabolism) (Jacotot and al., 1992). Arsenic is known above all for his toxicity.

5.14 Strontium (Sr, AMU=87.6)

This chapter is based on books and works of the following authors: Cabrera and al., 1999; Henrotin and al., 2001; Baron and al., 2002; Brown, 2003; Takahashi and al., 2003; Pi and al., 2004.

Despite a lack of data in the literature, strontium seems to play a role in bone metabolism. Strontium absorption rate varies with age (from 90% in infants to 10% in the elderly). Transport mechanisms remain unclear but a passive diffusion and a carrier-mediated way have been suggested.

Strontium has an anabolic effect on bone, acting on both osteoblasts and osteoclasts. Although molecular targets are still unknown, it has been suggested that Sr could act via calcium sensing-receptors. Sr could be able to inhibit bone resorption and stimulate bone formation. Various strontium salts are investigated or even already used in order to treat some bone diseases (e.g. strontium ranelate and S12911-2). It is also suggested that Sr could increase cartilage matrix formation (by stimulating proteoglycan synthesis).

5.15 Fluorine (F, AMU=19)

Fluorine does not have a particular metabolic function but it is essential to teeth and bone growth and maintaining. Fluorapatite is also incorporated in bones but is less soluble than calcium hydroxylapatite. Thus, bone is more resistant to resorption by osteoclasts. It also increases osteoblasts activity. By contrast, long-term high fluorine intake (notably in drinking water) can lead to potentially severe bone problems (skeletal fluorosis). (Sarazin et al., 2000; Martin, 2000)

5.16 Cadmium (Cd, AMU=112.4)

Cadmium absorption rate is quite low (from 3 to 5%) but it is efficiently retained in the kidney and liver in the human body. Besides its toxicity, especially to kidney, cadmium has physical features similar to calcium. So it could have a negative impact on bone metabolism. Cd can cause bone demineralisation through direct bone damage or indirectly. For example, it stimulates bone resorption by inhibiting renal hydroxylation of vitamin D in kidney (it inhibits the hydroxylation of calcidiol into calcitriol). (Sarazin et al., 2000; Wang and al., 2003; Zhu and al., 2004; Alfvén and al., 2004)

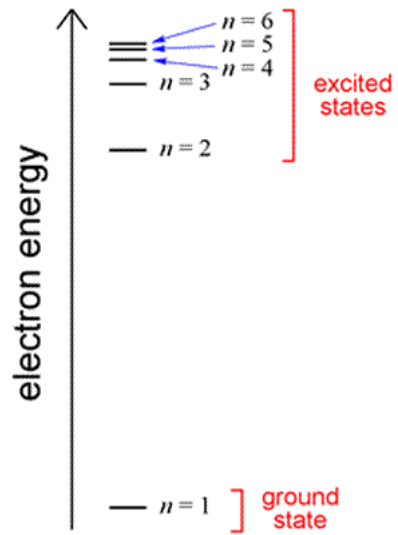

Figure 8 Energy levels of an electron (Cronk).

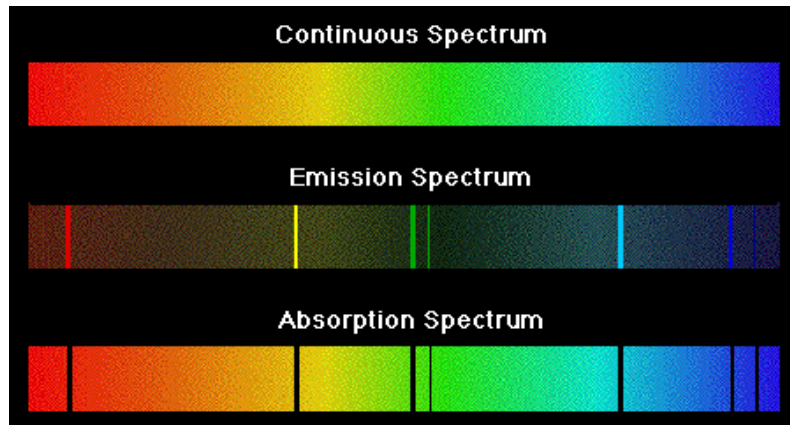

Figure 9 Example of spectra (Yost and al.).

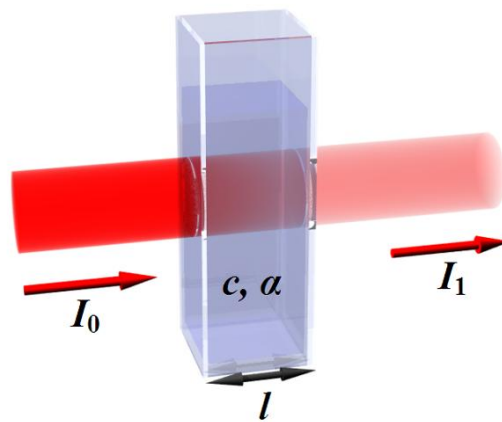

Figure 10 Illustration of the Lambert-Beer's law (Wikipedia).

6 Methods used for elements quantification

This chapter is based on books and works of the following authors: Welz and al., 1999; Skoog and al., 2008; Thomas, 2008.

6.1 Atomic Absorption Spectrometry

6.1.1 Principles

Atomic absorption spectrometry (AAS) is an optical method for detection and quantification of atomic elements. The theory of this method is based on the energy levels of outer electrons (Figure 8). According to the quantum mechanics, electrons are distributed over several atomic orbitals differing by their energy level. When electrons are in their primary level of energy, it is called the ground state. It is possible to promote an outer electron from its primary orbital to another higher orbital (excited state) by supplying a set quantity of energy in the form of radiation (specific wavelength), this phenomenon is called excitation. If enough energy is supplied, the electron leave orbitals and the atom becomes ionized. Each kind of transition requires a specific amount of energy, allowing its identification. Following this, every element has a different atomic absorption spectrum depending on the specific transitions occurring (Figure 9). Thus, one can identify an element by the mean of its unique atomic absorption spectrum which is characterized by several narrow absorption lines corresponding to several transitions. Normally, atomic lines should be very narrow, with a determined λ and a short $\Delta\lambda$. But three natural phenomena are responsible of a basal enlargement:

- The Heisenberg uncertainty principle: $\Delta\nu \times \Delta t \geq 1$;
- The Doppler effect (ν increases when particle come near the detector and ν diminishes when particle move away from detector);
- The Lorentz effect (pressure effect with high temperatures).

This is a quantitative method according to the Lambert-Beer's law (Figure 10). The quantity of absorbed radiation is proportional to the concentration of the element, in a certain concentration range. Lambert-Beer's relation is also depending on the absorption coefficient of the element and on the path length. The Lambert-Beer's relation:

$$I = I_0 \cdot e^{-c \cdot \alpha \cdot l}$$

$$A = -\log T = \log \frac{I_0}{I} = \varepsilon \cdot l \cdot c$$

With:

- I = intensity of the beam of radiation leaving the sample
- I_0 = intensity of the incident beam of radiation
- c = concentration
- α = absorptivity of the substance (element, molecule)
- ε = molar absorptivity

- l = path length
- T = transmittance
- A = absorbance, linearly related to the concentration of the analyte

If there are no interactions between species, the additivity principle is applied:

$$A_{tot} = A_1 + A_2 + \dots + A_n$$

$$A_{tot} = \varepsilon_1 \cdot b \cdot c + \varepsilon_2 \cdot b \cdot c + \dots + \varepsilon_n \cdot b \cdot c$$

The law presents some limitations:

- At high concentration (of analytes, or even of electrolytes), molecules are too close and each one affects the charge distribution of its neighbours. The absorptivity could be modified and the wavelength of the radiation absorbed could be shifted. It results in a deviation from the linear relationship.
- Deviations could also occur if dissociation or association equilibria are involved and if one of the products has no similar abilities to absorb a given wavelength. A typical example is the acid base indicators.
- The absorptivity (and the molar absorptivity) varies with the wavelength and normally this law strictly applies with a monochromatic source radiation. However, around the maximum absorption of an analyte, the molar absorptivity change little with wavelength and the divergences from Lambert-Beer's law are not significant.

The quantification of an element required a calibration curve made with the desired element.

6.1.2 Sources of instrumental noise

Spectrophotometric methods are limited in accuracy due to instrumental noise. Noise is due to random errors and can be evaluated by the following expression:

$$\frac{s_c}{c} = \frac{0,434 \cdot s_T}{T \cdot \log T}$$

Uncertainties (random errors, s_T) are classified into three categories depending on how they are affected by T :

- Type 1: $s_T = k_1$, uncertainty is independent of T . This type of error comes from a limited readout resolution, from the heat detector Johnson noise (thermal agitation of electrons) and from a dark current and amplifier noise.
- Type 2: $s_T = k_2 \sqrt{T^2 + T}$, which comes from the photon detector shot noise (encountered wherever electrons or charged particles cross a junction).
- Type 3: $s_T = k_3 \cdot T$, errors coming from the cell positioning uncertainties and the source flicker noise (causes are not yet known but it is recognizable by its frequency dependence). This noise can be minimized with double beam spectrophotometers or by using a constant-voltage power supply.

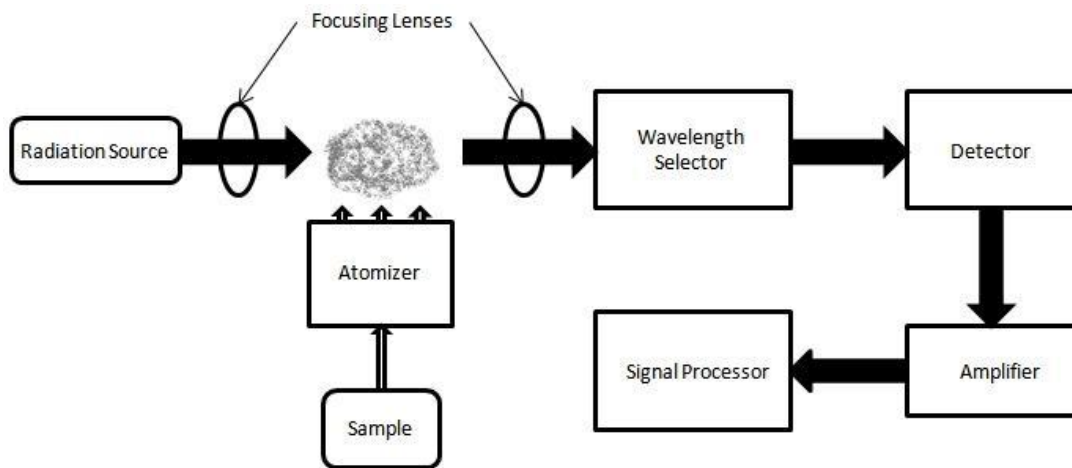

Figure 11 General diagram of an atomic absorption spectrometer (Wikipedia).

Table 4 Properties of different types of flame (Skoog et al., 2008).

Fuel	Oxidant	Temperature °C	Maximum burning velocity cm s ⁻¹
Natural gas	Air	1700-1900	39-43
Natural gas	Oxygen	2700-2800	370-390
Hydrogen	Air	2000-2100	300-440
Hydrogen	Oxygen	2550-2700	900-1400
Acetylene	Air	2100-2400	158-266
Acetylene	Oxygen	3050-3150	1100-2480
Acetylene	Nitrous oxide	2600-2800	285

6.1.3 Instrumentation

Atomic absorption spectrophotometers could be with single beam design or dual beam design. In a single beam design, the sample absorbance is measured by comparing light intensity without sample in the flame with the intensity after passing through the atomized sample. This method absolutely needs a blank (sample with all reagents and solvent but without analytes). Dual beam spectrophotometers allow measuring the blank and the sample at the same time. It is more expensive than the single beam apparatus. Figure 11 represents the general diagram of an atomic absorption spectrometer.

The sample has to be representative of the material from which it was taken. For solid samples, a pre-treatment is necessary and consist in dissolution by mineralization. There are two main ways of mineralization, the wet process and the dry process. The dry process consists in calcinations. The wet process is performed by combined acids such as aqua regia (nitro-hydrochloric acid) or a mix between nitric acid and hydrogen peroxide. The wet mineralization could be enhanced by the use of a microwave oven that reduces the mineralization time. The mineralization process could lead to losses and recoveries test is therefore recommended.

6.1.3.1 Atomizer

The first step for atomic absorption spectrometry analysis is the atomization. It is the most critical step because of the complexity of the processes that occurs. There are two most common methods of sample atomization: the flame atomization and electrothermal atomization. Other types of atomizer exist: inductively coupled argon plasma (ICP), Direct current argon plasma (DCP), Microwave-induced argon plasma (MIP), glow-discharge plasma (GD), electric arc and electric spark.

6.1.3.1.1 Flame atomization

During flame atomization several processes occur. The liquid sample is introduced by a nebulizer and undergoes a desolvation to produce a solid molecular aerosol. Then the aerosol is volatilized into gaseous molecules. The next critical step is to supply enough energy to dissociate the gaseous molecules into atoms without ionization. Nevertheless, some molecules will not dissociate and some atoms will be ionized. Moreover, a fraction of the molecules, atoms and ions are excited by the energy of the flame leading to emission spectra. Those phenomenons limit the precision of the method. Different types of flame are used according to the temperature required to atomize an element (Table 4).

The burning velocity is an important parameter for the flame stability. The best stability is reached when the flow velocity and the burning velocity are equals.

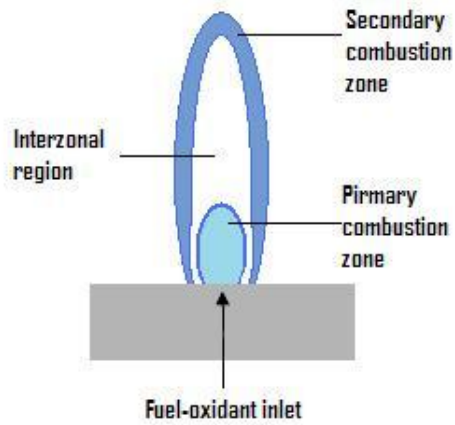

Figure 12 Schema of the 3 regions in a flame.

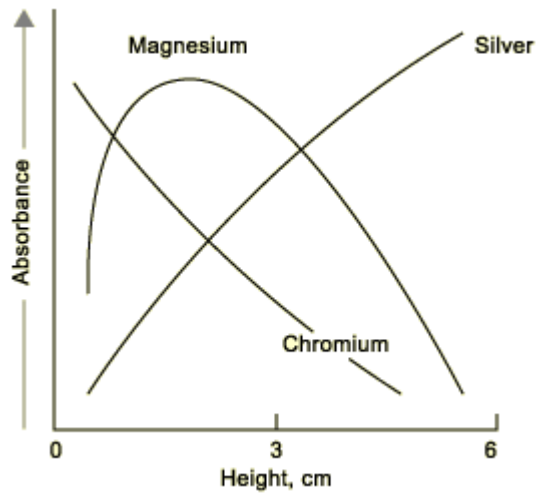

Figure 13 Examples of flame absorption profiles (Skoog et al., 2008).

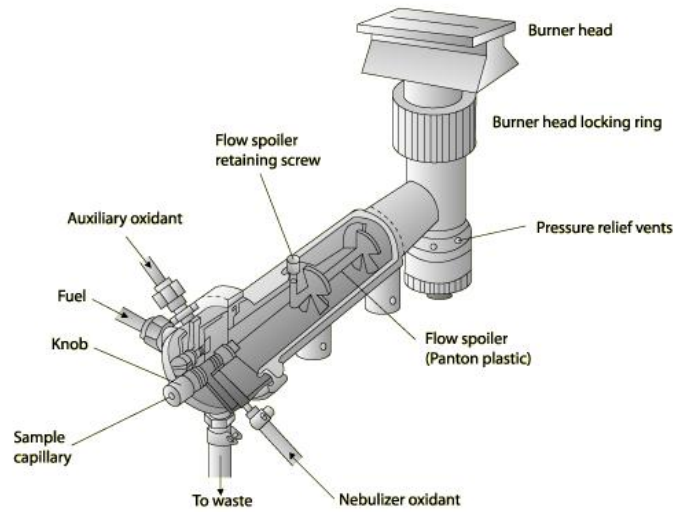

Figure 14 A laminar-flow burner. (Skoog et al., 2008)

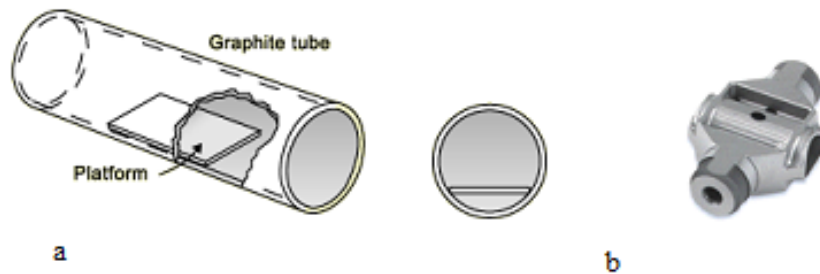

Figure 15 a) Internal view of graphite tube; b) THGA graphite furnace (Perkin-Elmer Life and analytical Sciences, Shelton, CT.).

The type of fuel and oxidant as well as the fuel-to-oxidant ratio has a great influence on the flame structure. The appearance and the relative size of these regions could vary considerably. Nevertheless, one can distinguish 3 regions in a flame (Figure 12). The maximum temperature is located in the interzonal region, which is the most widely used part of the flame for spectroscopy because of the prevalence of free atoms. In the primary combustion zone the thermal equilibrium is not yet accomplished. A blue luminescent hydrocarbon flame burns due to the band emission of C_2 , CH and other radicals. The secondary combustion zone is a conversion zone of the inner products into stable molecular oxides.

Each element has its own absorbance profile along the interzonal region. Profiles depend on the facility of atomize an element, and its propensity to be oxidized. Thus the maximum of absorbance of one element is located in the interzonal region and depends on the absorbance profile (figure 13).

Figure 14 represents an example of a typical laminar-flow burner used for AAS. Nebulizer is made by a simple concentric tube. The aerosol is formed by the flow of oxidant and is carried along baffles by the fuel. Baffles remove all the droplets which are evacuated into a waste container. The mix (aerosol, oxidant and fuel) is then going up in the flame through the slotted burner head. The flame presents a good compromise between stability and optical path (as long as possible; the Lambert-Beer law is proportional to the optical path).

6.1.3.1.2 Electrothermal atomization

Electrothermal atomizers are composed by an electrically heated graphite tube or graphite cup. A few microliters of sample is dropped off, evaporated at low temperature, ashed at higher temperature and then atomized in a range of temperature from 2000°C to 3000°C. The measure of the atomic vapour is made just above the heated surface.

The furnace (Figure 15) is water-cooled, and two gas flows are supplied in order to prevent the outside air from entering and incinerating the tube and to carry away generated vapours.

The graphite furnace AAS shows several advantages compared to the flame AAS:

- Higher sensitivity due to a short time of atomization and a longer residence time of the atoms in the optical path;
- Higher conversion efficiency of sample into free atoms;
- Low samples volumes (0,5 to 10 μ l);
- Possibility to analyze directly solid samples.

But this method present also some disadvantages:

- Longer measurement time than flame (several minutes in front of a few seconds);
- Lower relative precision (5% to 10% compared with 1% for the flame);
- High matrix interference which can be decreased by the use of graphite tubes coated by pyrolytic carbon;
- A relatively narrow dynamic range (frequently < two orders of magnitude).

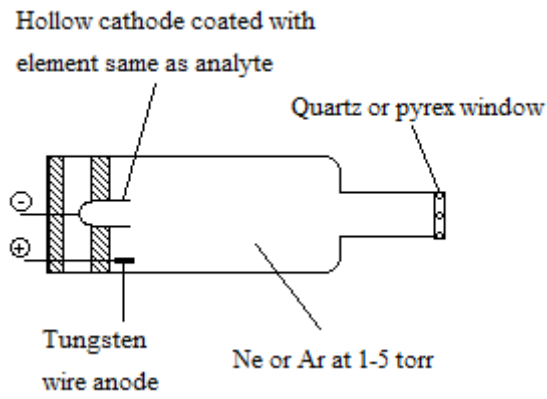

Figure 16 Schematic of a hollow-cathode lamp.

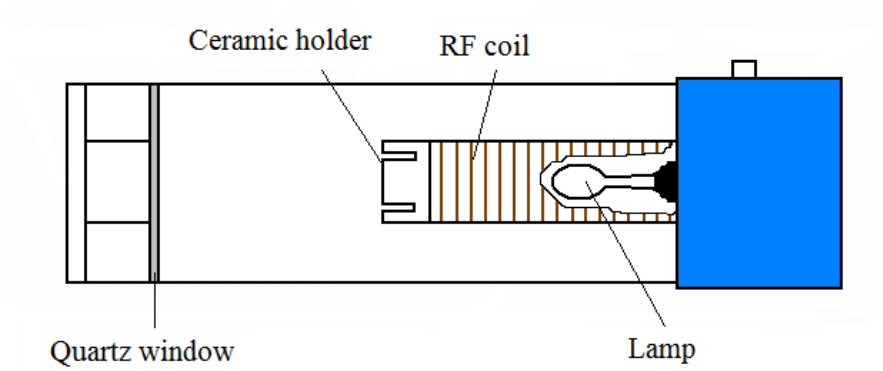
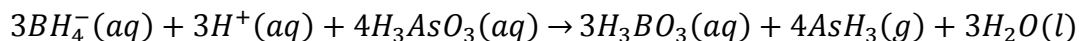

Figure 17 Schematic of an electrodeless discharge lamp.

6.1.3.1.3 Hydride generation

Hydride generation techniques enhance the detection limits for several elements (As, Sb, Sn, Se and Bi). These toxic elements are atomized as gases in a safe and efficient manner. The typical reaction of volatile hydrides generation is:



Volatile hydrides are carried by an inert gas into a heated silica tube leading to the atomization of hydrides.

6.1.3.1.4 Cold-vapour generation

This method consists in a reduction of Hg^{2+} in Hg_0 . Hg vapours are carried with a flow of argon to a long-pass absorption tube (quartz). Measurement is made in this tube at 253.7 nm.

6.1.3.2 Radiation sources

The absorbance coefficient (α) of the Lambert-Beer relation varies with the wavelength. So a polychromatic radiation induces deviation from Lambert-Beer's law. In order to keep a linear calibration curve in AAS, a line source is required. A line source, contrary to a continuum source, emits radiations with bandwidths narrower than the absorption line width. For a particular element, one just has to choose a line source with an emission line corresponding to an absorption line of the element and filter this wavelength with an inexpensive monochromator. The main disadvantage is the need of a separate source lamp for each element or group of elements.

The most common source used in AAS is the hollow-cathode lamp (Figure 16). The anode is made in tungsten. The cathode is coated with the element that's being analyzed. Both are hermetically sealed in a glass tube filled with neon or argon at a low pressure (1 to 5 torr i.e. 133 to 666 Pa). A high difference of potential is applied causing the ionization of the gas. Energetic gas cations hit the cathode and dislodge some of the metal atoms. This phenomenon is called *sputtering*. A part of these atoms became excited and return to the ground state while emitting a characteristic radiation. The higher the voltage, the higher the current and the greater the intensity. However, it leads to more unexcited sputtered atoms able to absorb the radiation emitted by the excited ones.

Electrodeless discharge lamps (EDLs) can also provide atomic line emission with higher intensities than the hollow-cathode lamps (Figure 17). They are composed of a sealed quartz tube containing a low pressure of inert gas (commonly argon) and a small quantity of the metal (or one of its salt) of interest. Argon is ionized and accelerated by an intense electromagnetic field (radio-frequency or microwave). Gaseous ions hit and excite the metallic atoms which emit the desired radiation. EDLs have better detection limits for some elements such as Se, As, Cd and Sb. For the other elements, it seems that hollow-cathode lamps have higher performances.

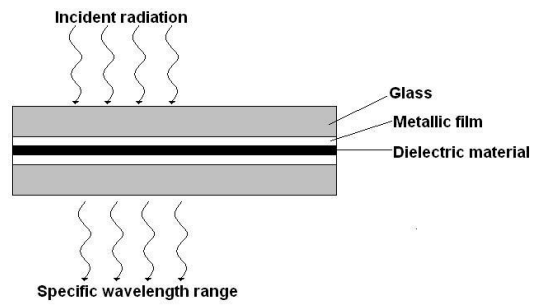

Figure 18 Schematic of an interference filter (University Of California).

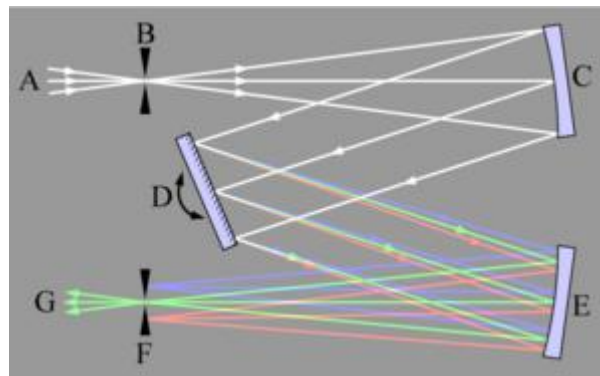

Figure 19 Czerny-Turner grating monochromator. A: incident beam; B: entrance slit; C-E: concave mirrors; D: reflection grating; F: exit slit; G: outgoing beam (Wikipedia).

6.1.3.3 Source modulation

In AAS, the flame emits radiations. A part of these radiations can cause interferences because of its wavelength. In order to eliminate this interference, the output of the source is modulated in alternating signal (by an alternating current or by a circular metal disk chopping the beam between the source and the flame). So the detector receives two signals, an alternating one from the source and a continuous one from the flame. Then a basic high-pass RC filter gets rid of the unmodulated signal.

6.1.3.4 Wavelength selectors

There are two main types of wavelength selector: filters and monochromators.

Interference filters (Figure 18) consists of a transparent dielectric layer between two semitransparent metallic films. The whole is sandwiched between two glass plates. Those filters are based on the principle of constructive and destructive interferences. The desired radiation runs into constructive interference while the others run into destructive interference. Interference filters are characterized by the selected wavelength, the percent transmittance and their effective bandwidth (about 1.5% of the wavelength).

Absorption filters are cheaper. They absorb selected portions of a continuous spectrum. They are made of coloured glass (great thermal stability) or of dye suspended in gelatine and sandwiched between glass plates. Effective Bandwidths range from 30 to 250 nm. Filters with the narrowest bandwidth have a low percent transmittance (about 10%). Cut-off filters have great transmittances (about 100%) in a part of the spectrum and very low transmittance (about 0%) in the rest of the spectrum. Two or more filters can be coupled.

Monochromators (Figure 19) have a great advantage. They are able to scan the spectrum, i.e. to continuously vary the selected wavelength. Main components of monochromators are slits, lenses, mirrors and gratings or prisms.

The rotation of the grating enables to select the wavelength. An echellette grating (the most common type) is made of a hard, optically flat, polished surface that has a large number of parallel and closely spaced grooves. The wavelength is selected depending on the incident angle, the reflected angle and the distance between two grooves.

The width of the slits has also an influence on the monochromators' resolution. It will delimit the effective bandwidth.

6.1.3.5 Radiation transducers (detectors)

An ideal transducer should have several properties:

- High sensitivity and high signal-to-noise ratio;
- High reliability and ease of use;
- Constant response over a broad range of wavelengths;
- A fast response time and a zero output signal in the absence of illumination;
- A proportional relation between the signal and the radiant power.

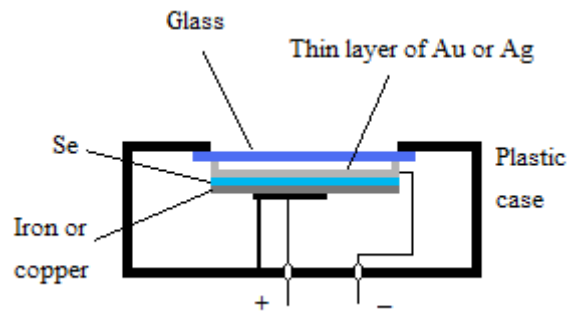

Figure 20 Schematic of a typical barrier-layer photovoltaic cell.

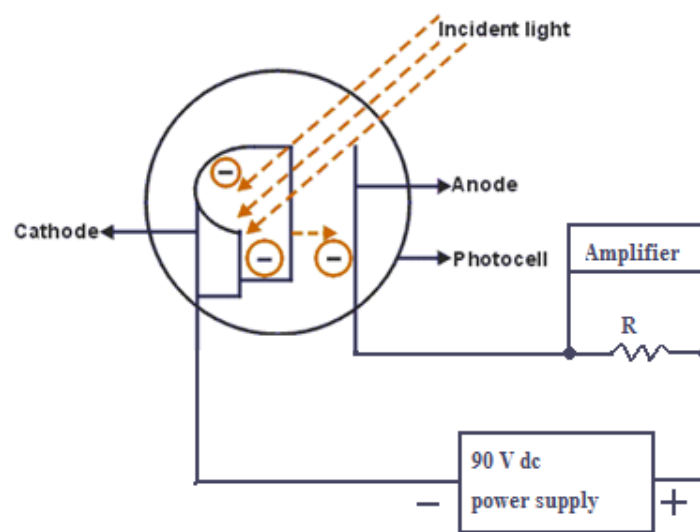

Figure 21 Schematic of a vacuum phototube.

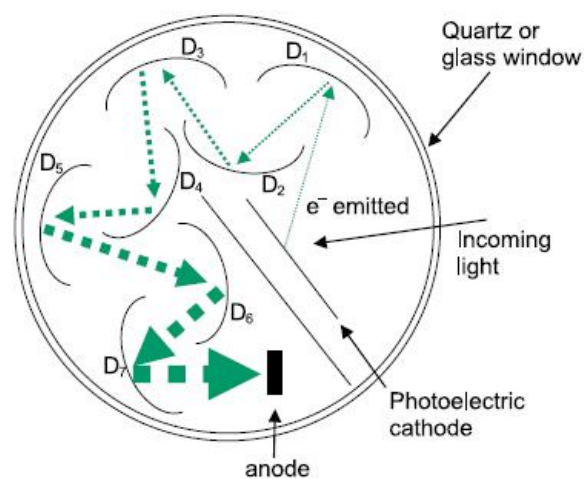

Figure 22 Cross sectional schematic of a photomultiplier tube

(D. W. Ball, Field Guide to Spectroscopy, SPIE Press, Bellingham, WA (2006)).

Nonetheless, most of real transducers present a small current in the absence of radiation called *dark current*.

There are two main types of detectors, the photon transducers (or photoelectric detectors) and the thermal transducers. Photon transducers have an active surface that absorbs radiation. The absorbed energy causes a photocurrent by emitting electrons or enhances conductivity by promoting electrons into conduction bands. Those transducers are principally used for measurement of UV, visible and near-infrared radiation. The thermal transducers, which are used for infrared radiation, respond to the average power of the incident radiation. Their sensitivity is lower than the sensitivity of photon transducers, but the latter has not a constant response versus wavelength.

6.1.3.5.1 Most commonly used photon transducers in AAS

The barrier-layer photovoltaic cells (Figure 20) are able to measure radiations in the visible region with a maximum sensitivity at about 550nm. This transducer is made of a flat copper or iron electrode on which is deposited a layer of semiconducting material (e.g. Se). The semiconductor is coated by a thin transparent metallic electrode (Au or Ag). The whole is protected by a glass plate and a plastic cage. Electrons and holes are formed in the semiconductor when a radiation of sufficient energy strikes it. Electrons can migrate through the external circuit and an electric current is generated. This current is proportional to the number of photons reaching the semiconductor. This kind of transducer is rugged and inexpensive. It keeps a good ability of measurement at high levels of illumination but has a poor sensitivity at low-levels.

Vacuum phototubes (Figure 21) are semicylindrical cathode, coated with a photoemissive material, and a wire anode both sealed into a transparent envelope under vacuum. A voltage is applied across the electrodes and when a photon strikes the cathode, an emitted electron flows to the anode generating a current. Again, the current is related to the power of the incident light. The sensitivity is better than for photovoltaic cells but a dark current is observed (thermal effect).

The photomultiplier tube is almost universally used as the detector type in AAS.

Photomultiplier tubes are appropriate for the measurement of low radiant power. They have also a photoemissive cathode and a wire anode but they have *dynodes*. Dynodes are maintained at a voltage more positive than the cathode (90 V). When electrons coming from the cathode arrived near a dynode they are accelerated. Each photoelectron striking dynodes causes the emission of several additional electrons which amplify the current. Too much intense light can cause irreversible damages and photomultiplier tubes have to be kept away from day-light. Moreover, these transducers suffer from dark current too.

Silicon photodiodes transducers (Figure 23) are made of a reversed-biased *pn* junction with a central depletion layer formed on a silicon chip. When radiations arrived on the chip, they caused holes and free electrons in the depletion layer. Because of the voltage applied, a current proportional to radiant power is generated. Silicon photodiodes are more sensitive than vacuum phototubes but less sensitive than photomultiplier tubes. They have a spectral range from 190 to 1100 nm.

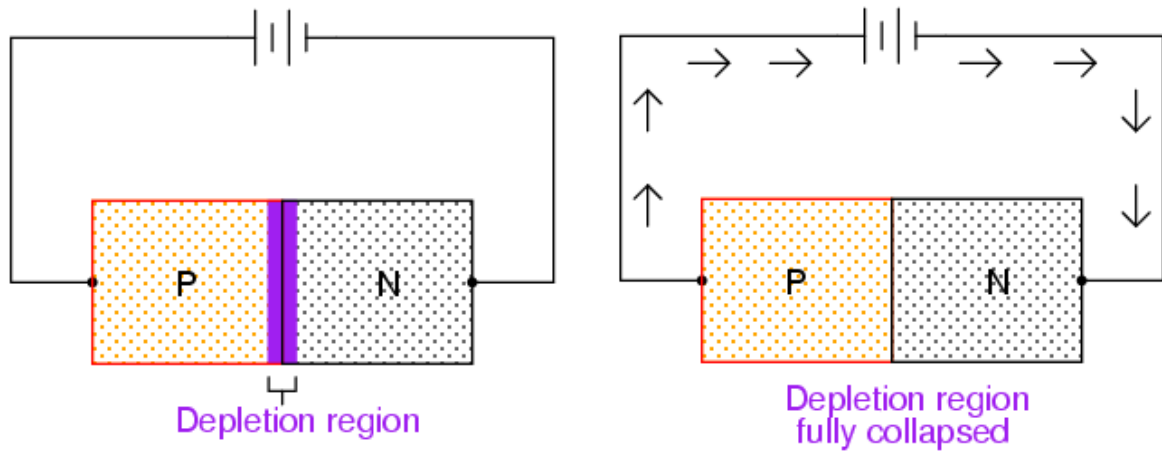

Figure 23 Schematic of a silicon photodiode transducer (Kuphaldt, 2002).

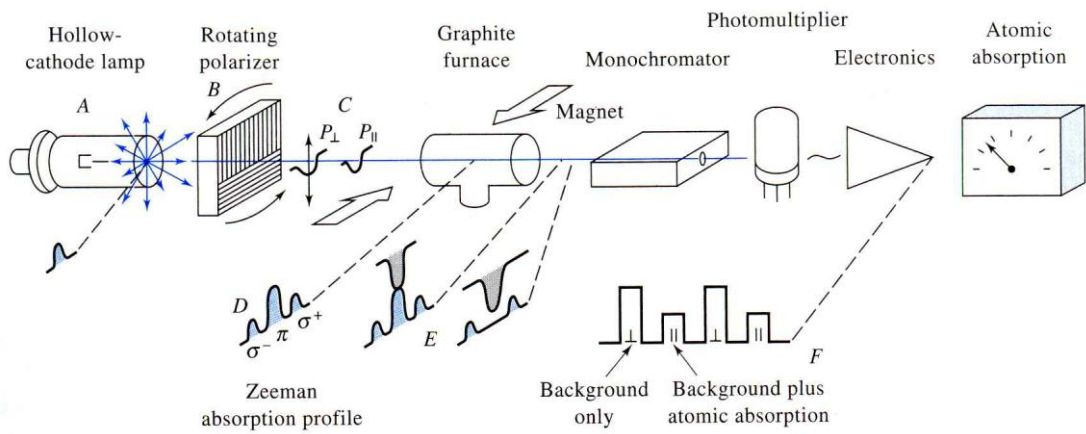

Figure 24 Schematic of an electrothermal atomic absorption instrument that provides a background correction based on the Zeeman effect (Skoog et al., 2008).

6.1.3.6 Amplifiers and signal processors

Electrical signal is amplified and eventually converted (ac/dc) by electronic device. A signal processor could also change the phase of the signal, filter it and execute mathematical operations. Readouts are usually cathode-ray tubes, LCD panels or computer displays.

6.1.4 Interferences in atomic absorption spectrometry

Two kinds of interferences occur in AAS, spectral interferences and chemical interferences.

6.1.4.1 Spectral interferences

Spectral interferences take place when atom or molecule (different from the analyte) absorb or emit radiations overlapping or lying so close to the analyte absorption (or emission) line. Sometimes, broad absorption band due to matrix components could reduce the power of the transmitted beam. It could be eliminated by changing the flame temperature or by measuring a blank. Products of atomization could lead to non-specific interferences mainly due to scattering. However, spectral interferences are quite rare in AAS because of the narrowness of the emission lines of sources. Moreover, if some interference occurs, it can be avoided by changing the analytical variables (e.g. flame temperature, fuel-to-oxidant ratio).

Several methods have been developed for correcting spectral interferences caused by matrix products. One method consists to provide a second radiation line as close as possible of the absorption line as reference. This radiation will not be absorbed by the analyte but if interferences occur, it might be affected. This decrease in power is then used to correct the absorbance of the analyte line.

A second method uses a continuous source (deuterium lamp) for background correction in electrothermal atomization. Radiations from each source pass alternately through the electrothermal atomizer. The attenuation of the continuous source reflects the broadband absorption or scattering by the sample matrix components. Thus, it is subtracted from that of the analyte beam and the background correction is achieved.

Another background correction in electrothermal atomization is based on the Zeeman effect (Figure 24). The principle of the Zeeman effect is the decomposition of spectral lines in a magnetic field. Absorption (or emission) lines are generally symmetrically decomposed into three lines. Most of time, the graphite furnace is surrounded by a permanent strong magnet (0.8 Tesla) that splits the electronic energy levels of analyzed atoms into several absorption peaks. For example, the decomposition pattern of a singlet transition leads to a multiplet composed of a central π line and to equally spaced satellite σ lines called σ^+ and σ^- . These lines are polarized. The beam source is plane-polarized into two components at 90° from each other by a rotating polarizer. The original absorption line of the analyte corresponds to the central π line. When the source radiation is polarized similarly, the analyte and the interfering components absorb the emitted radiation. During the other part of the cycle, no analyte absorption can occur because the π line does not appear in this polarized plan, only σ lines are present in this plan. Thus, the interfering components can absorb in the σ lines. Then, a subtraction between the two absorbances (analyte & background – background) gives the analyte absorbance.

6.1.4.2 Chemical interferences

Chemical interferences are more frequent. They involve thermodynamic equilibria such as formation of compounds of low volatility, dissociation and ionization.

Some anions form low volatility compounds with the analyte. It results in a decreasing atomization rate and leads to lower results. Some cations could also be implicated. These interferences can be eradicated or reduced by raising the temperature. Another way is to add *realizing agents* which are reactive species that react preferentially with the interferant. Four common reagents are LaCl_3 , EDTA, 8-hydroxyquinoline and APCD (ammonium salt of 1-pyrrolidinecarbodithioic acid).

A part of the dissociation and association reactions seems reversible and could be treated by the laws of thermodynamics. These reactions lead to equilibrium between the atom and oxide forms. Thus the absorbance, depending on the atomized form, is influenced by the shift of the equilibrium.

Ionization is quite rare in flames with air as oxidant. When oxygen or nitrous oxide is used, free electrons are produced according to this equilibrium:

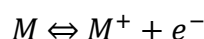

Formation of ions disturbs the absorption spectra. It could be solved by adding an ionization suppressor or ionization buffer. These products release easily large amounts of free electrons so that the previous equilibrium is shifted to the left. An example is the use of NaCl in the quantification of potassium, or the increasing sensitivity when strontium is analyzed with small amounts of potassium.

6.2 Atomic emission spectrometry

6.2.1 Principles

Atomic absorption spectrometry (AES) is based on the fact that excited atoms emit lights at specific wavelengths (Figure 8). In this method no emitting source is used. Samples are atomized by different sources such as flame, plasma, arc or spark. Wavelengths emitted by atoms are processed in the same way as in AAS.

6.2.2 Inductively coupled plasma source (ICP)

A typical ICP source, called torch, consists in three concentric quartz tubes. The inner tube is for sample introduction and nebulization. The gas which forms the plasma flows through the outer and the middle tubes. Between the middle and the inner tubes flows the auxiliary gas. The three gases cited above are generally argon (Ar). Depending on the torch design, the total flow rate of Ar consumption ranges from 5 to 20 l/min.

A radio-frequency inducted coil surrounds the top of the torch. It radiates from 0.5 to 2 kW at generally 40.68 MHz. The coil is water-cooled. Argon flow is first ionized by a spark when passing through the torch. Then, ions and electrons are caught up and accelerated by the fluctuating magnetic field. This interaction results in other ionization in chain reaction.

High temperatures (6000 to 10 000K) are raised due to ohmic heating of the plasma. As well as for a flame, a temperature profile exists in the plasma.

Due to high temperatures, degradation of molecules and atomization is more complete. Despite, a limited ionization occurs which could be explain by the ionization equilibria. Indeed, an important concentration of electron (coming from ionised Ar) is present in the plasma shifting the equilibrium to the left (6.1.4.2).

Emission spectra obtained are more complex than in AAS because of hundreds or even more emission lines. It is advantageous concerning specificity but it also increase the probability of spectral interferences.

Although ICP-AES has higher resolution, equipments and operating costs are more expensive than in AAS and procedures are heavier.

6.3 Ultraviolet-Visible Molecular Spectrometry

For further details refer to *Principles of instrumental analysis* (Skoog et al., 2008).

6.3.1 Principles

The Lambert-Beer's law is applied but instead of absorption lines, broad bands of absorption are observed. In atomic absorption, line spectra are due to electronic transitions. In molecular absorption, other phenomenons are responsible of radiation absorption. The general pattern consists into a two step process, first an electronic excitation of the molecule by radiation and after a relaxation leading to deexcitation:

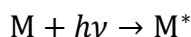

Relaxation could also lead to a decomposition of M^* into new species or in a reemission of fluorescence or phosphorescence.

Electronic excitation concerns valence or bonding electrons. Several types of transition occur:

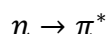
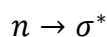
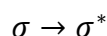
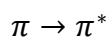

It could also be due to a transition between filled and unfilled d-orbitals of transition metal ions.

Because of its unique composition, each molecule has a unique shape of spectrum including a wavelength of maximum absorbance called λ_{max} . A given reactive molecule can be quantified, thanks to Lambert-Beer's relation, at a wavelength as close as possible from λ_{max} .

II. Material and methods

1 **Choice of families and sampling**

Ten families from two distinct areas were chosen in KBD asbl-vzw database according to several criteria:

- High KBD prevalence area (Figure 1);
- Presence of a 3 to 5 years old child. At this age, children are likely to contract the disease;
- This child must have a KBD sibling included in a previous study. Children having an affected sibling are more likely to contract the disease (Suetens et al., 2001).

Families were numbered from 1 to 10 followed by the KBD database reference number.

A sampling campaign has been done on two periods: January/February 2010 (winter) and May 2010 (spring). The most eaten foods were collected in each family. The sampling included:

- Roasted barley flour
- Wheat flour
- Black tea
- Rice
- Potatoes
- Yak (or cow) butter.

Foods were taken at the top of the container in order to get closer to conditions of consumption. Two more foods were bought in Lhasa: Chinese cabbage and plastic noodles (a kind of instant noodles). The reason is that families buy these foods in Lhasa.

Samples were collected in single-use plastic bags and stored in a place safe from humidity. The day after the sampling, fresh foods (Chinese cabbage and potatoes) were cut up, dried at 105°C in an air oven until unchanging weight and blended. The dry matter of each food was determined upon the unchanging weight method. The fresh food drying and a part of the dry matters were carried out in the laboratory of mycology in the CDC building of Lhasa. Balance used in T.A.R. was a *HF-2000G A&D Weighing*. The rest of the dry matters were done in the *Unit of Analytical chemistry in Gembloux Agro Bio Tech, University of Liège*. The analytical balance used there was an *AE 200 Mettler* and the two air ovens were type *U 30* and *UFB 500* from *Memmert*.

2 Nutritional survey

A small nutritional survey was performed by the mean of a prospective questionnaire. This questionnaire, made of pictures of the most common foods, was given to the parents. They were asked to fill in the 24 hours child food consumption. During the collect, questionnaires were checked (translation and interpretation) and some precisions were added with help of KBD asbl-vzw team in T.A.R. Measurement of intake volumes has been made with water and graduated cylinder. The food or beverage container was filled up with water. Then water was transferred into the graduated cylinder.

3 Mineral elements analyses

The laboratory glassware used in this study is cleaned by a soak of a few hours in a 6N nitric acid bath and rinsed at least four times with distilled water.

The sampling portion was about one gram weighted with analytical balance (*AE 200 Mettler*) in a Teflon container from a model *HPR 1000/6* rotor. 6 ml of 65% nitric acid (AnalR Normapur, VWR Prolabo) and 1 ml of 35% hydrogen peroxide (analytical reagent, *Merck*) were added. The whole has a microwave assisted mineralization in a *High performance Microwave Digestion unit, MLS 1200 mega* from *Milestone* with *MLS Mega 240* terminal, *EM 45 A* exhaust module and *FAM 35* fumes absorbing module. The adopted microwave program was the following:

- 250 W : 2 min
- 0 W: 2 min
- 250 W: 6 min
- 400 W: 5 min
- 600 W: 5 min
- Ventilation: 10 min

This program is based on the provider's advice for use. It was optimized for mineralization of plant products by Pr. J-P. Barthélemy.

The rotor is cooling down during one hour. Then, the mineralized solution is quantitatively transferred into a 50 ml volumetric flask and diluted to volume with ultrapure water. Teflon containers were rinsed at least 3 times with ultrapure water.

About black tea infusions, more or less 10 grams weighted with analytical scale (*AE 200 Mettler*) were seethed in 100 ml of ultrapure water during 1h30. Infusions were then filtered on folded filter papers MN 616 1/4 18.5 cm diameter from *Macherey-Nagel* and diluted to 250 ml with ultrapure water. A sample of 20 ml of this solution was transferred with a volumetric pipette into a Teflon container and directly mineralized in the aforementioned conditions.

Most of the elements were measured by atomic absorption spectroscopy (FAAS, ETAAS, hydrides generation and cold vapour generation) in the *BUREAU ENVIRONNEMENT ET ANALYSE DE GEMBLOUX (BEAGx. Dir.: Ir. Ph. Maesen)*. Most of Selenium analyses were below LOQ. In order to ensure the relevance of these results, they were also performed by inductively coupled plasma atomic emission spectroscopy (ICP-AES) in the *Walloon Agricultural Research Centre (CRA-W), Agricultural Product Technology Unit (Head of unit: Ph.D. G. Sinnaeve, Laboratory Manager: Ph.D. J-M. Romnee)*.

A flame atomic absorption spectrometer (FAAS) *Perkin-Elmer 1100 B* was used for Na, K, Ca, Mg, Zn, Fe, Mn, Cu, Ni, Pb, Sr, Mo and Al analyses. Dilutions with spectral buffer LaCl_3 2 g/l + HNO_3 2% were done for Ca, Mg, Na, Mo and Al. For K, a solution of CsCl 2g/l + HNO_3 2% was used. When dilutions were required for other elements, a solution of ultrapure water with HNO_3 2% was used. Dilutions were performed with a diluter *microlab[®] 500 series* from *Hamilton*. A back ground correction method with deuterium lamp (6.1.4.1 Spectral interferences) is applied except for Na, Ca and K.

An electrothermal atomic absorption spectrometer (ETAAS) *Perkin-Elmer AAnalyst 800* with *P-E AS 800 autosampler* was used for Cu, Ni, Cd, Pb, Cr and Co analyses. A matrix modifier from *Bernd Kraft GmbH* ($\text{Pd}+\text{Mg}/\text{HNO}_3$ 2 M) is also used. A back-ground correction method is applied, based on the Zeeman Effect (6.1.4.1 Spectral interferences).

Lamp sources used were hollow cathode *P-E lumina lamps*.

Arsenic and Selenium were measured by the hydride generation method (HG). 2 ml of a solution of a 5% KI/ascorbic acid solution (KI for analysis from *Fisher*, ascorbic acid for analysis from *Acros organics*) and 1 ml of HCl 37% (analytical reagent, *Merck*) were added to 2 ml of mineralized solutions. No KI is added for Selenium analysis. The whole was homogenized and let to reduction during 45 min before to dilute to 10 ml with ultrapure water. Samples were analyzed on a *Perkin-Elmer AAnalyst 800* equipped with a quartz cell and with a *P-E As 90plus autosampler*. Reagent solutions for hydride generation were HCl 10 % and NaBH_4 0.5% (for As) or 0.02% (for Se) + NaOH 0.005%.

Mercury was analysed by cold vapour generation (Co.Vap.) on a *P-E FIMS-400* equipped with a *S10 autosampler*. A sample portion of 5 ml was taken.

Calibration curves were made of multi element standards solutions from *Bernd Kraft GmbH*. Except for phosphorus and strontium which were made of KH_2PO_4 (for analysis) and $\text{Sr}(\text{NO}_3)_2$ (for analysis) from *Merck*.

Table 5 and Table 6 list the technical features for elements measured by FAAS method. Table 8 lists the technical features for elements measured by ETAAS. Table 9 presents furnace programs in ETAAS. Table 7 lists the technical features for elements measured by hydride generation and cold vapour generation methods. They have been established in BEAGx for common analysis of these elements in different matrices and have been adapted from recommended methods (Perkin Elmer, *Analytical Methods for Atomic Absorption Spectrometry*, 1982, Supplement).

For FAAS analyses:

- the read delay is 1 s (except for Ca which is 2 s);
- the signal processing is hold;
- 3 replicates are done;
- Integration time is 1 s;
- Calibration is linear and units are mg/l.

AA-BG signifies atomic absorption minus background correction. The slit width is written with letter H or L. It corresponds to the position of receptor and signifies high or low.

In ETAAS, signal is measured in term of peak area. In hydride generation and in cold vapour generation, signal is measured in term of peak height.

Table 5 Technical features for flame-AAS analyses.

	Na	K	Ca	Mg	Fe
Flame	C ₂ H ₂ /air	C ₂ H ₂ /air	C ₂ H ₂ /air	C ₂ H ₂ /air	C ₂ H ₂ /air
Fuel	2.9 l/min	2.5 l/min	2.5 l/min	2.5 l/min	2.5 l/min
Oxidant	8.0 l/min	8.0 l/min	8.0 l/min	8.0 l/min	8.0 l/min
Wavelength (nm)	588.9	765.5	422.7	285.2	248.4
Slit (nm)	0.2 H	0.2 H	0.7 H	0.7 H	0.2 H
Technique	AA	EMISS	AA	AA-BG	AA-BG
Lamp current (mA)	8	0	7	4	20

Table 6 Technical features for flame-AAS analyses.

	Zn	Mn	Sr	Mo	Al
Flame	C ₂ H ₂ /air	C ₂ H ₂ /air	C ₂ H ₂ /air	C ₂ H ₂ /N ₂ O	C ₂ H ₂ /N ₂ O
Fuel	2.6 l/min	2.5 l/min	2.5 l/min	6.0 l/min	6.2 l/min
Oxidant	8.0 l/min	8.0 l/min	8.0 l/min	8.0 l/min	8.0 l/min
Wavelength (nm)	213.8	279.5	460.7	313.2	309.3
Slit (nm)	0.7 H	0.2 H	0.2 H	0.7 H	0.7 H
Technique	AA-BG	AA-BG	AA-BG	AA-BG	AA-BG
Lamp current (mA)	10	15	15	20	18

Table 7 Technical features for hydride generation method and cold vapour method.

	As	Hg
Wavelength (nm)	193.7	253.7
Low slit (nm)	0.7	/
Signal Type	AA	AA
Read Parameters:		
Time (s)	15	15
Delay Time (s)	0	0
Boc Time (s)	2	2
Pump 1 speed	100	100
Pump 2 speed	120	120
Sample diluent	10% (v/v) HCl	3% (v/v) HCl
Reductant	0.2% NaBH ₄ in 0.05% NaOH	0.2% NaBH ₄ in 0.05% NaOH
Carrier Solution	10% (v/v) HCl	3% (v/v) HCl
Carrier Gas Flow (ml/min)	50-100	40-70
Reaction coil	110 mm x 1.0 mm I.D.	
Sample Volume (μl)	500	500
Cell Temp (°C)	900	/

Table 8 Technical features for graphite furnace ETAAS analyses.

	Pb	Cr	Co	Cd	Ni	Cu
Wavelength (nm)	283.3	357.9	242.5	228.8	232	324.8
Slit (nm)	0.7 L	0.7 L	0.2 L	0.7 L	0.2 L	0.7 L
Signal Type	AA-BG	AA-BG	AA-BG	AA-BG	AA-BG	AA-BG
Read Parameters:						
Time (s)	5	5	5	5	5	5
Delay Time (s)	0	0	0	0	0	0
BOC Time (s)	2	2	2	2	2	2
Replicates	1	1	1	1	1	1
Volume (μl)	20	20	20	20	20	20

Table 9 Furnace programs for ETAAS analyses.

	step	temp (°C)	ramp time	Hold Time	Internal Flow
Pb	1	110	1	30	250
	2	130	15	30	250
	3	850	10	20	250
	4	1600	0	5	0
	5	2450	1	3	250
Cr	1	110	1	30	250
	2	130	15	30	250
	3	1650	10	20	250
	4	2500	0	5	0
	5	2500	1	5	250
Co	1	110	1	30	250
	2	130	15	30	250
	3	1400	10	20	250
	4	2400	0	5	0
	5	2450	1	3	250
Cd	1	110	1	30	250
	2	130	15	30	250
	3	500	10	20	250
	4	1500	0	5	0
	5	2450	1	3	250
Ni	1	110	1	30	250
	2	130	15	30	250
	3	1100	10	20	250
	4	2300	0	5	0
	5	2450	1	3	250
Cu	1	110	1	30	250
	2	130	15	30	250
	3	1200	10	20	250
	4	2000	0	5	0
	5	2450	1	3	250
	6	20	1	1	250

Phosphorus was measured by UV-Vis spectrophotometry at 700 nm on a *UV-1205 Shimadzu* with *Epson LX-300* printer, using the Scheele method:

1. Reagents.

- Solution I:

- 1 g methanol
- 5 g $\text{Na}_2\text{SO}_3 \cdot 7\text{H}_2\text{O}$ or 2.5 g anhydrous Na_2SO_3
- 137 g $\text{Na}_2\text{S}_2\text{O}_5$
- Warm slightly, cool down and dilute to 1 l with distilled water.

- Solution II:

- 50 g ammonium heptamolybdate dissolved by warming at $\pm 60^\circ\text{C}$ and then cooled down at room T°
- 140 ml concentrated H_2SO_4
- Dilute to 1 l with distilled water.

- Solution III:

- 340 g $\text{NaAc} \cdot 3\text{H}_2\text{O}$ or 205 anhydrous NaAc diluted to 1 l with distilled water.

2. Solutions for calibration curve.

- 1000 mg/l P_2O_5 solution: 1.9195 g KH_2PO_4 diluted to 1 l with ultrapure water.

- 100 mg/l P_2O_5 solution: 5 ml of 1000 mg/l solution diluted to 50 ml with ultrapure water.

- 0-5-10-20 mg/l P_2O_5 solutions for calibration curve:

- 0-0.5-1-2 ml of 100 mg/l solution
- 1 ml of solution I
- 1 ml of solution II
- Shake up and wait 15 min
- Add 2 ml of solution III
- Dilute to 10 ml with ultrapure water.

Measure within one hour.

3. Measurement of samples

Depending on expected phosphorus concentrations, pour a sample ranging from 200 μl to 5 ml in a 10 ml flask and add:

- 1 ml of solution I
- 1 ml of solution II
- Shake up and wait 15 min
- 2 ml of solution III
- Dilute to 10 ml with ultrapure water.

Measure within one hour.

4 Validation of the method

The method (mineralization and measurement) has been validated via certified reference materials (CRM). Two CRM, *White cabbage BCR[®]-679* and *Wheat flour ERM[®]-BC382*, have been bought from the *European Institute for Reference Materials and Measurements* (Geel, Belgium). Those CRM have been chosen on the basis of their composition and the certified reference values. They included all desired elements (except Se) and had matrices the closest from samples matrices. Certified reference materials have been processed and analysed following the same procedure as samples. Measurement of each element has been performed as referred above. Depending on the element, four to eight repetitions have been done. Dry matters have been determined following instructions of the provider. The analysis of CRM allowed us to measure the trueness and the fidelity of the analytical procedure for the elements of interest.

5 Evaluation of daily intakes

An estimation of daily intakes has been performed by the mean of a nutritional software called Kidmenu[®] at the *Queen Fabiola Children's University Hospital (ULB)* in the *Dietetics area* (Chief Dietician: Martine Robert, Head of clinic: Pr. Ph. Goyens). This estimation was based on the nutritional survey, on the minerals measurements and on a previous nutritional study (de Voghel, 2008).

Kidmenu[®] is software containing foods database. File contains much information about a given food such as energetic content, protein, lipid and carbohydrates contents but also a few minerals content. New files can be created and edited. This work was based on Tibetan foods files created by de Voghel, 2008. Mineral contents were modified according to the food mineral results. This software also allows creating anamnesis. In dietetics, anamnesis is a file containing some information about a person, such as name, birth date, weight, height, etc. Menus can be editing for a person having an anamnesis. These menus are composed from food files. Combining information, the software calculates the nutrients intake for a given person and a given menu. These intakes are automatically compared to encoded references tables.

Comparisons of estimated daily intakes were done with reference tables from the *Institute of Medicine of the National Academies* (refer to chapter 5.1 Daily references intakes).

III. Results and discussion

1 Choice of families and sampling

Ten families were founded in two Counties. Five are from Nimo County and five from Lhundrop County, which are high KBD prevalence areas. Each family included a three to five years old child (except for two families for which children were 6.5 and 2.5 years old) having an KBD brother or sister (reasons are referred in p.38).

A sample of each food was taken in every family, once in January and once in May. It frequently happened that one or several foods missed in a family. Chinese cabbages both in January and in May were bought in the same store in Lhasa. As plastic noodles are industrial food products, they were supposed to be standard. None was taken in May.

Fresh foods like potatoes and Chinese cabbage were cut up and dried the day after the sampling. Dry matters were measured on the other foods. Dry matters of certified reference materials were also measured. In Table 10 and Table 11 are presented the dry matters expressed in percentages. Dry matters are more or less equals to those referenced in USDA tables or Souci tables (for Black Tea). Only barley flour values are a bit distant from the reference.

Table 10 Dry matters (%) of foods and comparison with reference tables.

Dry Matters (%)	Barley flour		Wheat flour		Potato	
	January	May	January	May	January	May
1_49	91	92	86	87	20	21
2_45	94	91	87	88	/	23
3_66	95	93	87	88	21	20
4_2	92	95	86	88	/	/
5_22	94	94	88	88	/	25
6_746	92	93	86	88	24	26
7_568	93	93	88	88	27	27
8_860	92	93	/	89	31	27
9_636	94	93	87	89	25	24
10_703	94	94	86	90	27	27
Mean±SD	93±1	93±1	87±1	88±1	25±4	24±3
USDA tables	88		88		23	
	Barley flour or meal		Wheat flour, white, all-purpose, unenriched		Potato, boiled in skin, flesh without salt	

Table 11 Dry matters (%) of foods and certified reference materials and comparison with reference tables.

Dry Matters (%)	Rice		Black tea		Chinese cabbage (from Lhasa)	
	January	May	January	May	January	May
Family number						
1_49	86	86	91	89	3.6	3.2
2_45	/	87	90	90	USDA	5.6
3_66	/	/	91	90	Chinese cabbage (pe-tsaï)	
4_2	84	85	89	90	Plastic Noodles	
5_22	87	88	90	91	January	May
6_746	87	/	92	91	97	/
7_568	86	87	89	89		
8_860	/	88	90	90	CRM Wheat	
9_636	87	88	91	91	88.5	
10_703	/	89	91	/	CRM Cabbage	
Mean±SD	86±1	87±1	90±1	90±1	96.7	
USDA tables¹	87¹		91-93²		Souci tables²	
	Rice, white, short-grain raw ¹		Black Tea ²			

2 Nutritional survey

The 24 hours food intake of each child has been checked and written down. Members of the KBD staff in T.A.R helped to translate. Each menu is summarized in tables below.

One can notice that diet is principally based on grains such as barley, wheat and rice. Potato is also important. The consumption of meat and dairy products (milk, cheese, fermented milk) is extremely rare. A small amount of butter is daily ingested under the form of yak butter tea. Because fruits are not local productions and are quite expensive, eating these products is occasional.

Cooking pot recipes differ from one family to another. However, main ingredients are recurrent and there is a general pattern shared by every family. Each recipe generally contain barley or wheat flour (under the form of noodle or raw) and vegetables (most of the time wild vegetables, Chinese cabbage or radish). Lipids are supplied by animal fats (butter, meat fat) or vegetable oils (e.g. rapeseed oil). About 5g/ 100mg of meat (yak, cow, goat or sheep) are sometimes added (de Voghel, 2008).

Brewed black tea and butter tea are the most common beverages although some child drinks great amounts of *chang*, a local made alcohol (industrial *chang* is 3% alc. vol.). Tibetans consume a lot of salt, principally in butter tea but also in cooking pot.

Tsampa is a dish made of barley flour and water. Salt and butter are sometimes added. *Momo* is a kind of Tibetan ravioli stuffed with vegetables and sometimes meat. *Kapsee* is a kind of cookie or bread roll mad of barley or wheat flour. (de Voghel, 2008).

The total food intake is sometimes very low, especially in May, because parents are working in fields all-day.

Table 12 Food intakes of child number 1_49.

Date of interview	27/01/2010_28/01/2010		10/05/2010_11/05/2010	
Food	Volume (ml)	Number	Volume (ml)	Number
Tsampa	/	/	155	3
Butter tea	140	3	155	4
Black tea	145	1	155	3
Momo	/	3 ¹	/	6 ¹
Potatoes	/	/	/	2
Rice	/	/	155	2
Cheese	/	/	/	Yes ⁴
Fruits	/	Yes ²	/	2 ⁵
Candies	/	1	/	10
Cooking pot	210	3 ³	155	1 ³
<i>Other :</i>	no milk no yoghurt		no milk no yoghurt	

¹ steamed

² two bytes of apple and five jujubes

³ meat + wild vegetables + wheat flour

⁴ a bit in tsampa

⁵ apples

Table 13 Food intakes of child number 2_45.

Date of interview	27/01/2010_28/01/2010		10/05/2010_11/05/2010	
Food	Volume (ml)	Number	Volume (ml)	Number
Tsampa	225	2	245	3
Butter tea	225	2	245	3
Black tea	225	2	245	1
Potatoes	/	3 ¹	/	/
Roasted barley	/	9 ²	/	/
Candies	/	1	/	/
Cooking pot	225	2 ³	245	2 ⁵
<i>Other :</i>				
Meat	/	2 ⁴	/	/
Instant bean noodles	225	1	/	/
	no milk no yoghurt		no milk no yoghurt	

¹ from the neighbours

² child handles

³ nettles + animal fats + barley flour

⁴ boiled cow

⁵ meat + wheat noodles

Table 14 Food intakes of child number 3_66.

Date of interview	27/01/2010_28/01/2010		10/05/2010_11/05/2010 ³	
Food	Volume (ml)	Number	Volume (ml)	Number
Tsampa	180	1	130	2
Butter tea	180	1	130	1
Black tea	180	1	130	1
Momo	/	1 ¹	/	/
Potatoes	/	6	/	/
Candies	/	2	/	/
Cooking pot	180	2 ²	/	/
<i>Other:</i>	Still a bit breast-feeding no milk no yoghurt		/ no milk no yoghurt	

¹ with meat² wheat noodles + meat + white radish³ food intake is really low because child had probably an angina**Table 15 Food intakes of child number 4_2.**

Date of interview	27/01/2010_28/01/2010		10/05/2010_11/05/2010	
Food	Volume (ml)	Number	Volume (ml)	Number
Tsampa	275	1	210	2
Butter tea	180	2	150	5
Black tea	180	3	/	/
Momo	/	/	/	1 ¹
Potatoes	/	1	210	1
Rice	275	1	210	1.5
Fruit	/	/	/	2
Roasted barley	/	/	/	1 ²
Cooking pot	/	/	210	1 ³
<i>Other :</i>				
Yoghurt	275	1	no yoghurt	
Bread	/	2	/	/
Wheat + butter+				
Sugar	275	1	/	/
Dry meat	/	/	/	2
Milk	no milk		150	2

¹ steamed² child handles³ meat + wheat noodles

Table 16 Food intakes of child number 5_22.

Date of interview	27/01/2010_28/01/2010		10/05/2010_11/05/2010	
Food	Volume (ml)	Number	Volume (ml)	Number
Tsampa	175	4	220	2
Butter tea	140	2	185	4
Momo	/	/	/	3 ²
Rice	/	/	220	1
Chang	/	/	sip	2
Candies	/	3	/	1
Cooking pot	175	1 ¹	220	1 ³
<i>Other :</i>	no yoghurt no milk		no yoghurt no milk	

¹ barley flour +animal fats + radish

² with meat

³ wheat noodles + animal fats + radish

Table 17 Food intakes of child number 6_746.

Date of interview	1/02/2010_2/02/2010		5/05/2010_6/05/2010	
Food	Volume (ml)	Number	Volume (ml)	Number
Tsampa	240	1	115	2
Butter tea	130	3	150	3
Black tea	130	1	/	/
Momo	/	/	/	3 ⁴
Potatoes	/	7	/	/
Rice	240	2	/	/
Chang	130	2	85	3
Roasted barley	/	1 ¹	/	1 ¹
Candies	/	4	/	1
Cooking pot	240	1 ²	115	1 ⁵
<i>Other :</i>	no yoghurt no milk		no yoghurt no milk	
Fried bread	/	2 ³	/	/

¹ child handles

² barley noodles + yak meat + radish

³ made of wheat, 8g /piece

⁴ steamed

⁵ barley noodles + vegetables + radish

Table 18 Food intakes of child number 7_568.

Date of interview	1/02/2010_2/02/2010		5/05/2010_6/05/2010	
Food	Volume (ml)	Number	Volume (ml)	Number
Tsampa	140	3	/	/
Butter tea	70	3	90	3
Black tea	/	/	90	2
Potatoes	/	5	/	3
Chang	140	10	130	4
Candies	/	1	/	/
Cooking pot	140	4 ¹	265	1 ⁴
<i>Other :</i>				
Bread	/	3 ²	/	/
Yak sausage	/	a few ³	/	/
	no yoghurt no milk		no yoghurt no milk	

¹ wheat noodles + meat + cabbage + radish

² made of wheat, 8g /piece

³ small pieces

⁴ from restaurant: wheat noodles + meat + vegetables

Table 19 Food intakes of child number 8_860.

Date of interview	1/02/2010_2/02/2010		5/05/2010_6/05/2010	
Food	Volume (ml)	Number	Volume (ml)	Number
Tsampa	155	2	210	2
Butter tea	50	3	140	1
Black tea	50	1	140	3
Momo	/	3 ¹	/	1 ¹
Potatoes	/	9	/	4
Rice	155	1	210	2
Chang	130	4	65	3
Candies	/	/	/	1
Cooking pot	155	2 ²	210	2 ⁴
<i>Other :</i>				
Bread	/	2 ³	/	/
	no yoghurt no milk		no yoghurt no milk	

¹ steamed

² barley noodles + meat + vegetables

³ made of wheat, 8g /piece

⁴ wheat noodles + vegetables

Table 20 Food intakes of child number 9_636.

Date of interview	1/02/2010_2/02/2010		5/05/2010_6/05/2010	
Food	Volume (ml)	Number	Volume (ml)	Number
Tsampa	150	1	130	1
Butter tea	145	2	130	2
Black tea	/	/	130	1
Momo	/	/	/	2 ⁴
Potatoes	/	/	/	3
Rice	150	1	130	3
Cheese	/	/	/	1 ⁵
Fruit	/	1 ¹	/	/
Candies	/	/	/	5
Cooking pot	150	2 ²	130	1 ⁵
<i>Other :</i>				
Fried bread	/	2 ³	/	/
	no yoghurt no milk		no yoghurt no milk	

¹ orange

² wheat noodles + meat + green cabbage

³ made of wheat, 8g /piece

⁴ steamed

⁵ wheat noodles + a bit of cheese

Table 21 Food intakes of child number 10_703.

Date of interview	1/02/2010_2/02/2010		5/05/2010_6/05/2010	
Food	Volume (ml)	Number	Volume (ml)	Number
Tsampa	260	1	/	/
Butter tea	70	1	65	3
Black tea	70	1	/	/
Rice	/	/	310	2
Roasted barley	/	1 ¹	/	1 ¹
Candies	/	/	/	1
Cooking pot	260	1	310	2
<i>Other :</i>				
	no yoghurt no milk		no yoghurt no milk	

¹ child handles

² barley noodles + yak fat + green vegetables

³ meat + wheat noodles

3 Analyses of foods mineral contents

3.1 Limits of quantification

Limits of quantification (LOQ) have been calculated on eight blanks following this method:

$$LOQ = \bar{x}_{blanks} + 10 \cdot s_{blanks}$$

With \bar{x}_{blanks} = average of blanks and s_{blanks} = standard deviation of blanks.

Outliers have been highlight and set aside via the Grubb’s test (Miller and al., 2005). This statistical test allows eliminating some values based on the average, the suspected value and the standard deviation (SD):

$$Z = \frac{|mean - suspected\ value|}{standard\ deviation}$$

In this method, mean and SD are calculated including the suspected value. If Z is greater than the reference value found in tables, the suspected value can be considered as an outlier.

Reference value depends on the effective number.

Table 22 Limits of quantification in mg/kg of dry matter by element and by period of analysis, n=8.

LOQ: mg/kg Dry Matter										
January	P	Ca ¹	Mg	Fe	Zn	Cu	Mn	Se ¹	Na	K
	200	60	20	10	1.5	0.5	7.5	0.1	15	350
	Ni	As ¹	Sr	Mo	Cd ²	Pb ³	Hg ³	Al ³	Cr ³	Co ³
	5	0.05	55	15	0.01	0.5	0.05	20	2	0.5
May	P ¹	Ca	Mg ¹	Fe	Zn	Cu	Mn	Se	Na	K
	50	30	10	10	3	0.65	1	0.05	35	60
	Ni	As ¹	Sr	Mo	Cd	Pb ³	Hg ³	Al ³	Cr ³	Co ³
	0.41	0.02	8.8	11	0.05	0.5	0.03	30	0.5	0.5

¹ n=7 ² n=6 ³ n=3

One can notice that most of LOQ are lower in May. It is due to the calculation method of LOQ. Indeed, several blanks analyses have been performed for both periods. Mean values and standard deviations are different what is leading to different LOQ.

3.2 Validation of the method

Certified reference materials have been processed and analysed following the same procedure as samples. Datas have been corrected (sample weight and dry matter) and expressed in mg/kg of dry matter (DM). Comparison of measurement results with the certified value has been done following a procedure described by Linsinger, 2005. This procedure can be shortly described as follow: the first step is to calculate Δ_m , the difference between the certified value (C_{CRM}) and the mean measured value (C_m):

$$\Delta_m = |C_m - C_{CRM}|$$

Then, the combined uncertainty of result and certified value (u_{Δ}) is given by adding the uncertainty of the measurement result (u_m) and the uncertainty of the certified value (u_{CRM}). Uncertainties are expressed in standard deviation but only the variances are additive. The uncertainty u_{CRM} is obtained by dividing the SD (s_{CRM}) by the coverage factor (k). A coverage factor is a security factor associated to the uncertainty in order to get into an interval of a given level of confidence. A coverage factor $k=2$ defines an interval having a level of confidence of approximately 95%. The uncertainty u_m is obtained by dividing the SD (s_m) by the square root of the number of measurements (n):

$$u_{\Delta} = \sqrt{u_m^2 + u_{CRM}^2}$$

$$u_m = s_m / \sqrt{n}$$

$$u_{crm} = s_{CRM} / k$$

The expanded uncertainty (U_{Δ}) is given by multiplication of u_{Δ} by a coverage factor (k , usually equal to 2):

$$U_{\Delta} = 2 \cdot u_{\Delta}$$

There is no significant difference between the “experimental” result and the certified value if:

$$\Delta_m \leq U_{\Delta}$$

Certified values and “experimental” results for each element are listed in Table 23:

Table 23 Comparison of measurement results with certified values.

	<i>White cabbage BCR[®]-679</i> mg / kg (*µg / kg)			<i>Wheat flour ERM[®]-BC382</i> mg / g			Δ_m	U_{Δ}
	$C_{CRM} \pm s_{CRM}$	C_m	s_m	$C_{CRM} \pm s_{CRM}$	C_m	s_m		
P ¹				1.19 ± 0.07	1.26	0.01	0.071	0.071
Ca ²				0.21 ± 0.018	0.203	0.017	0.007	0.019
Mg ²				0.247 ± 0.010	0.253	0.011	0.006	0.013
Fe ²	55 ± 2.5	55.3	3.1				0.3	3.4
Zn ²	79.7 ± 2.7	81.6	2.8				1.9	3.4
Cu ³	2.89 ± 0.12	2.96	0.22				0.07	0.23
Mn ³	13.3 ± 0.5	13.7	0.8				0.4	0.8
Ni ⁴	27 ± 0.8	27.5	2				0.5	1.9
Sr ³	11.8 ± 0.4	7.6	0.5				4.3	0.6
Mo ³	14.8 ± 0.5	13.9	1.5				0.9	1.4
Cd* ⁴	1.66 ± 0.07	1.95	0.36				0.29	0.37
As* ⁵	6.7-7.3	5.8	3				/	/

¹ n=8

² n=7

³ n=5

⁴ n=4

⁵ no certified value

Although some molybdenum values were lower or close to LOQ, calculation was yet done with numeric values. Result shows that Mo analysis matches with the CRM referenced value. It could be explain by the fact that LOQ are slightly overestimated. Except for strontium and arsenic, there is no significant difference between certified values and “experimental” results. Indeed, Δ_m values are lower than U_Δ values. Sr difference could be due to a matrix effect in the presence of anions and acids. It could also be due to formation of monoxide (e.g. $SrAl_2O_4$, SrO) (Pinta and al., 1968).

Sr and As experimental results are lower than LOQ. Due to this, following datas about them are given as information, without quantitative guarantees.

Another step in the validation of the method consisted in evaluating the repeatability. Relative standard deviations (RSD) have been calculated on five repetitions of both CRM, and on five repetitions of the sample *barley flour 8_860* of January (Table 24). No RSD exceeded 10%. When mean values were below LOQ, % RSD were not calculated.

Table 24 Relative standard deviation by element, expressed in percentage, n=5.

	P	Ca	Mg	Fe	Zn	Cu	Mn
CRM:							
Mean value (mg/kg MS)	1271	205	252	57	81	3	13.7
% RSD	0.3	3.1	5	1.9	3.8	7.4	5.6
Barley flour 8_860:							
Mean value (mg/kg MS)	3863	593	1126	61	19.9	3.3	14
% RSD	0.6	2.2	0.7	3.3	2.3	10	5
	Se	Ni	As	Sr	Mo	Cd	
CRM:							
Mean value (mg/kg MS)	-*	27.5	<LOQ	<LOQ	<LOQ	2	
% RSD	-*	6.3	-*	-*	-*	1.2	
Barley flour 8_860:							
Mean value (mg/kg MS)	<LOQ	<LOQ	<LOQ	<LOQ	<LOQ	<LOQ	
% RSD	-*	-*	-*	-*	-*	-*	

CRM corresponds to *Wheat flour ERM®-BC382* for P, Ca and Mg

CRM corresponds to *White cabbage BCR®-679* for the other elements

* Measured results were below LOQ, % RSD were not calculated. No CRM were certified for Se content.

3.3 Linearity ranges and calibration curves

Linearity ranges are listed in Table 25 below. Linearity range is defined by the interval between LOQ and the upper limit of calibration curve (expressed in mg/kg or µg/kg). LOQ of May (generally lower) have been considered in this case.

Table 25 Linearity ranges of measured elements.

	FAAS			ETAAS/HG/CV	
	mg/kg			µg/kg	
	Lower limit	Upper limit		Lower limit	Upper limit
Na	35	250	Cu	650	2500
K	60	500	Ni	410	2500
P	50	218	Cd	50	250
Ca	30	500	As	20	500
Mg	10	50	Co	500	2500
Fe	10	250	Cr	500	1000
Zn	3	50	Hg	30	500
Mn	1	250	Pb	500	2500
Sr	8.8	250	Se ²	500	500
Mo	11	500			
Al	30	2500			

¹ Linearity range of Se concerns BEAGx analyses by AAS.

All determination coefficient (R^2) of calibration curves were higher than 0.998.

3.4 Samples analyses and comparisons with reference tables

Mineralizations of samples and elements concentrations measurements have been processed as referred in chapter II. Material and methods. Raw datas have been treated and expressed in mg/kg DM. Concentrations of each sample have been reported to the dry matter of this sample (not to the mean dry matter). Mean values and standard deviations have been calculated by element and by food. When “<LOQ” is written with grey font, it signifies that more than half of sample values are below LOQ. When mean or standard deviation is written with grey font, it signifies that a few sample values are below LOQ (but less than a half of the values).

They are listed from Table 26 to Table 33 and compared to values found into two reference tables. Reference tables are the following: *USDA National Nutrient Database* (US Departement of Agriculture, 2010) and *Souci Fachmann Kraut Food composition tables 1989/90* (Souci and al., 1989/90). In each table, the food the most similar to the one analyzed has been chosen for comparison.

Concerning barley flour (Table 26), Phosphorus content is a higher than value referenced in USDA table but roughly the same than value referenced in Souci table. However, reference food of USDA is more similar to analyzed food than the other reference food. So one can consider phosphorus level as high. About Ca, Mg, Zn, Cu and Mn, measured values are close to referenced values. Iron content is markedly higher than values referenced in both tables despite a great variation between samples.

On the contrary, selenium content in barley flour is clearly lower than values referenced in both tables. In January, Se was measured by the hydride generation method with a LOQ of 0.01 mg/100g of fresh matter (FM) and every sample was below this LOQ. In May, Se was measured by ICP-AES with a LOQ of 0.005 mg/100g FM and only one sample exceeded this LOQ (barley flour of family 1_49: 0.01 mg/kg FM). The nine others were below the LOQ (and some were even below the LOD). LOQ of Ni, Sr and Mo were too high to allow a measurement and a comparison with tables (except for Sr in May but no reference values exists). Generally, there are no important differences between January and May but Arsenic content is higher than European reference values (be it reminded that As values are not validated).

About wheat flour (Table 27), P, Ca, Mg, Zn, Cu and Mn are roughly equal to those referenced in tables. Iron content is lightly upper references but there is a great variation between samples (i.e. high standard deviation). The same observation has been made for barley flour; selenium content is lower than LOQ which is lower than referenced values. Only one sample exceeded the LOQ in May (wheat of family 9_636: 0.013 mg/kg FM). Most of Ni, As, Sr and Mo values are below the LOQ and no reference value exists for this food (except for As and Mo).

Mineral contents in potato are listed in Table 28. Iron content is slightly upper referenced values. Other values are generally close to Souci's values. Selenium content is lower than LOQ but in this case, LOQ are upper referenced values. Ni, Sr and Mo are still unquantifiable. Arsenic content in May seems to be a bit higher than the European upper limit.

Rice results are expressed in term of raw rice (i.e. no cooked) (Table 29). Some referenced values differ slightly from one table to the other. Rice values are generally close to values of one of the tables, depending on the element. Iron values differ from one table to another. Iron results also differ from January to May. Selenium is again lower than referenced values and LOQ. Ni, Sr and Mo are still unquantifiable. Mean Cadmium contents are approximately five times bigger than reference value, but one can notice that standard deviation in January is important.

Because Chinese cabbage is not cultivated by families but bought in cities, only one cabbage (bought in Lhasa) by campaign was analyzed (Table 30). So no standard deviation was calculated. Globally, measurement results are close to Souci's reference values. It seems to be some differences between January and May but it is difficult to evaluate without repetitions (confidence interval). Once again, Selenium is clearly lower than reference value and LOQ.

Concerning yak butter we have been faced with a problem. Mould contaminations appear during samples repatriation. Only two samples were not contaminated in January. Values listed in Table 31 are the average of those two measures and no standard deviation was calculated. No yak butter was sampled in May. Most of referenced values are below calculated LOQ. Iron content seems higher than referenced values.

Black Tea as powder or leaf is not referenced in USDA tables. Comparing to Souci's tables, phosphorus and copper contents are lower than referenced values (Table 32). On the contrary, calcium, iron and manganese values are greatly higher than references. Magnesium, Zinc and Nickel are close to references. As information, Arsenic content seems (no guaranteed quantification) more or less ten times higher than European reference in both periods. Cadmium is also clearly higher than referenced value.

Brewed black tea expressed as liquid doesn't exist in Souci's tables. Thus, these results were only compared with USDA tables (Table 33). Generally, measured values are really low, even lower than referenced values. In this case it is important to make clear that Tibetan have a special manner to brew tea. They brew a complete brick of tea (more or less 400g) with about 4l of water. It results in an extremely concentrated tea. It is stored like this and diluted approximately thirty times when consumed (Wangla, 2010). Measures have been performed on undiluted brewed tea and then corrected by the dilution ratio.

Table 26 Mineral contents of barley flour and comparison with reference tables.

mg /100g Fresh Matter	USDA National Nutrient Database	Souci-Fachmann- Kraut	Barley flour			
			January, n=10		May, n=10	
			Barley flour or meal	Barley, without husk, whole grain	Mean	S.D.
P	296	342	370	29	380	67
Ca	32	33-42	37	9	36	7
Mg	96	110-130	108	18	108	44
Fe	2.68	2-3.6	11.0	4.5	13.7	5.9
Zn	2.0	2.6-4.4	2.2	0.5	2.2	0.4
Cu	0.343	0.1-0.5	0.39	0.07	0.34	0.07
Mn	1.034	1.5-1.8	1.6	0.3	1.7	0.2
Se	0.0337	0.2-24	<0.01	/	<0.005	/
Na	4	6-29	17	15	13	5
K	309	371-521	586	28	466	45
Ni		0.01-0.11	<0.5	/	<0.5	/
As ¹	0.0133-0.0284		0.089	0.023	0.093	0.070
Cd ²	0.0171		<0.01	/	<0.05	/
Sr			<5	/	0.98	0.03
Mo		0.032-0.052	<1.5	/	<1.5	/

¹ As reference values are expressed in mg/kg DM (EFSA, 2009a).

² Cd reference value is expressed in mg/kg DM (EFSA, 2009b).

Table 27 Mineral contents of wheat flour and comparison with reference tables.

mg /100g Fresh Matter	USDA National Nutrient Database Wheat flour, white, all-purpose, unenriched	Souci-Fachmann- Kraut Wheat flour type 405	Wheat flour			
			January, n=9		May, n=9	
			Mean	S.D.	Mean	S.D.
P	108	74	113	19	146	49
Ca	15	13-16	24	7	25	3
Mg	22		26	9	36	16
Fe	1.17	1.95	3.5	2.7	4.4	2.4
Zn	0.7	1.1	0.8	0.20	1.0	0.4
Cu	0.144	0.15-0.43	0.19	0.04	0.22	0.07
Mn	0.682	0.74	0.87	0.1	1.01	0.25
Se	0.0339	0.019	<0.01	/	<0.005	/
Ni			<0.5	/	<0.045	/
As ¹	0.0133-0.0284		<0.05	/	<0.045	/
Cd ²	0.03		0.02	0.007	<0.05	/
Sr			<5	/	1.11	0.07
Mo		0.025-0.064	<1.5	/	<1.5	/

¹ As reference values are expressed in mg/kg DM (EFSA, 2009a).

² Cd reference value is expressed in mg/kg DM (EFSA, 2009b).

Table 28 Mineral contents of potato and comparison with reference tables.

mg /100g Fresh Matter	USDA National Nutrient Database Potato, boiled in skin, flesh, without salt	Souci-Fachmann- Kraut Potato	Potato			
			January, n=7		May, n=9	
			Mean	S.D.	Mean	S.D.
P	44	35-79	68	11	57	19
Ca	5	6.4-14	9	4	12	3
Mg	22	17-32	25	7	30	3
Fe	0.31	0.44-1.5	1.99	0.56	2.7	2.1
Zn	0.3	0.12-0.49	0.24	0.07	0.33	0.07
Cu	0.188	0.08-0.23	0.08	0.03	0.09	0.04
Mn	0.138	0.1-0.25	0.26	0.04	0.24	0.06
Se	0.0003	0.004-0.02	<0.002	/	<0.0015	/
Ni		0.005-0.056	<0.15	/	0.020	0.012
As ¹	0.0033-0.0156		<0.05	/	0.039	0.030
Cd ²	0.0211		0.016	0.007	<0.05	/
Sr			<1.4	/	<0.25	/
Mo		0.005-0.086	<0.4	/	<0.4	/

¹ As reference values are expressed in mg/kg DM (EFSA, 2009a).

² Cd reference value is expressed in mg/kg DM (EFSA, 2009b).

Table 29 Mineral contents of rice and comparison with reference tables.

mg /100g Fresh Matter	USDA National Nutrient Database	Souci-Fachmann- Kraut	Rice			
			January, n=6		May, n=8	
			Mean	S.D.	Mean	S.D.
	Rice, white, short- grain, raw	Rice polished				
P	95	100-140	99	11.7	98	8.0
Ca	3	3-10	6.9	0.9	7.0	0.9
Mg	23	64	22	6	18	4
Fe	4.23	0.4-0.8	0.55	0.1	2.1	0.8
Zn	1.1	0.2-0.8	1.3	0.2	1.2	0.13
Cu	0.21	0.13	0.22	0.06	0.17	0.04
Mn	1.037	1-3	0.93	0.12	1.03	0.09
Se	0.0151	0.01-0.07	<0.01	/	<0.005	/
Ni			<0.5	/	<0.045	/
As ¹	0.1362-0.1424		0.106	0.03	0.084	0.006
Cd ²	0.0253		0.147	0.107	0.12	0.05
Sr			<5	/	<1	/
Mo		0.04-0.11	<1.5	/	<1.5	/

¹ As reference values are expressed in mg/kg DM (EFSA, 2009a).

² Cd reference value is expressed in mg/kg DM (EFSA, 2009b).

Table 30 Mineral contents of Chinese cabbage and comparison with reference tables.

mg /100g Fresh Matter	USDA National Nutrient Database	Souci-Fachmann- Kraut	Chinese Cabbage	
	Chinese cabbage (pe-tsaï)	Chinese leaves	January	May
P	29	18-41	32	38
Ca	77	36-43	27	37
Mg	13	11-12	5.2	8.4
Fe	0.31	0.3-0.9	0.25	1.17
Zn	0.23	0.34	0.12	0.20
Cu	0.036	0.02	0.026	0.021
Mn	0.19	0.24-0.33	0.10	0.14
Se	0.0006		<0.0001	<0.0001
Ni			<0.02	0.005
As ¹	0.0029-0.0108		<0.05	<0.02
Cd ²	0.0231		/	0.09
Sr			0.32	0.07
Mo			<0.06	<0.05

¹ As food reference is Brassica vegetables, values are expressed in mg/kg DM (EFSA, 2009a).

² Cd food reference is leafy vegetables, value is expressed in mg/kg DM (EFSA, 2009b).

Table 31 Mineral contents of yak butter and comparison with reference tables.

	USDA National Nutrient Database	Souci-Fachmann-Kraut	Yak Butter	
mg /100g Fresh Matter	Butter, without salt	Butter (from cream and sour cream)	January, n=2	May
P	24	18-27	18	/
Ca	24	11.00-19.00	16	/
Mg	2	1.8-4.2	<2	/
Fe	0.02	0.03-0.2	0.19	/
Zn	0.09	0.23	<0.15	/
Cu	0.016	0.002-0.015	<0.05	/
Mn	0.004	0.0025-0.040	<0.7	/
Se	0.001	0.0003	<0.005	/
Ni		0.003-0.020	<0.5	/
As ¹	0.0055-0.0116		<0.005	/
Sr			<5	/
Mo		0.00-0.02	<1.5	/

¹ As reference values are expressed in mg/kg DM (EFSA, 2009a).

Table 32 Mineral contents of black tea and comparison with reference tables.

		Black Tea			
	Souci-Fachmann-Kraut	January, n=10		May, n=9	
mg /100g Fresh Matter	Black Tea	Mean	S.D.	Mean	S.D.
P	314	202	24	188	15
Ca	289-314	764	180	642	77
Mg	184	217	43	189	13
Fe	17.2	75	55	70	11
Zn	3.02	2.84	0.40	3.14	0.25
Cu	2.78	1.52	0.86	1.33	0.18
Mn	73.4	171	26	161	23
Se	0-0.006	0.019	0.007	/	/
Ni	0.51-0.76	0.92	0.11	0.78	0.08
As ¹	0.0595-0.0666	0.59	0.20	0.67	0.11
Cd ²	0.0325	0,21	0,03	0.28	0.10
Sr		<5	/	1.6	0.23
Mo	0.013	<1.5	/	<1.5	/

¹ As reference values are expressed in mg/kg DM (EFSA, 2009a).

² Cd reference value is expressed in mg/kg DM (EFSA, 2009b).

Table 33 Mineral contents of brewed black tea and comparison with reference tables.

mg /100g Fresh Matter	USDA National Nutrient Database Tea, brewed, prepared with distilled water	Brewed Black Tea (10 g FM with 100 ml of ultrapure water and diluted 30x)			
		January, n=10		May, n=9	
		Mean	S.D.	Mean	S.D.
P	1	0.07	0.01	0.06	0.01
Ca	0	0.11	0.03	0.11	0.01
Mg	1	0.16	0.08	0.19	0.04
Fe	0.01	0.007	0.003	0.005	0.0004
Zn	0.01	0.001	0.0003	0.001	0.0001
Cu	0.008	0.0003	/	0.0002	/
Mn	0.219	0.115	0.024	0.100	0.019
Se	0	/	/	<0.005	/
Ni		0.002	/	0.002	/
As ¹	0.0044	<0.0001	/	<0.0001	/
Cd ²	0.0041	<0.0001		<0.0001	/
Sr		<3.3x10 ⁻⁵	/	<3.3x10 ⁻⁵	/
Mo		<1.7x10 ⁻⁶	/	<1.7x10 ⁻⁶	/

¹ As values are expressed as liquid and come from *EFSA* (*EFSA*, 2009a).

² Cd reference value is expressed as liquid (*EFSA*, 2009b).

In summary:

- Iron content is markedly high in barley flour and black tea. It is also clearly higher than referenced values in wheat flour, potato and butter;
 - Selenium content is clearly lower than referenced value in barley flour, wheat flour, rice and Chinese cabbage;
 - Black tea (leaves) is rich in several elements (Ca, Fe and Mn) but brewed black tea is drunk so much diluted that mineral content is really low.
-

4 Evaluation of daily intakes

4.1 Creation of anamnesis, children's menus and edition of food files

Based on nutritional survey and on minerals measurements, daily intakes have been estimated by the mean of nutritional software called Kidmenu[®] (see chapter II.5). Anamnesis has been created for each child of the survey. It included:

- The child's name + number of family
- The gender
- The date of birth

For each child, two menus have been created on the software, one based on the nutritional survey of January and one based on the nutritional survey of May. Menus were based upon encoded Tibetan dishes. Dishes recipes were taken from de Voghel, 2008. They constitute a synthesis of a broad nutritional survey. They are reported to an edible portion of 100 g and listed in Table 34.

About menus, a decision was made to encode only dishes or foods for which mineral contents were measured. Thus, several items of the nutritional survey were not considered: candy, *chang*, fruit, *momo*, yak meat, yoghurt and milk. This decision was motivated by following reasons:

- Knowing that dairy products represent a significant contribution in Ca, they have not been considered for two reasons. The first one is because their consumption is quite rare (one child on ten consumed in January and two children on ten consumed milk in May). The second reason referred to the decision above, milk was not analyzed.
- Consumption of meat and fruits is likely to supply interesting amounts of minerals (especially of Zn and Fe in meat). However, their consumption is low. Two children consumed fruits in January and two children consumed fruits in May. Meat is rarely eaten as it is, but small amounts (about 5g, see Table 34) are added in dishes.
- The contribution of *chang* in daily intakes could be interesting because some children drink a lot. Unfortunately it has not been possible to analyze this food due to the difficulty of aerial transportation.
- Candies represent a small contribution in term of quantity.

To make it easier, dishes called cooking pot in the present nutritional survey has been standardized to two dishes: *tsamphruk* and *thukpa*, depending on the flour included (barley flour or wheat flour). If no flour was included but the dish contained yak meat, it was assimilate to *thukpa* (only one child is concerned in May).

Another approximation was made. The nutritional survey listed food intakes in term of volumes (ml). In the menus' edition, 100 ml of a given dish has been considered as 100 g of the dish. This approximation does not lead to an important error because most of dishes contain large amounts of water (e.g. butter tea, *tsamphruk*, *thukpa*).

Mineral content of the dishes have been calculated (by the software) on the basis of the food files. No mineral values were encoded for unanalyzed food files included in dishes recipes (such as water, rapeseed oil, rape leaf, etc.).

Table 34 Recipes expressed for 100 g of most common dishes of the survey.

Dishes	Food	Quantity	Unit	Dishes	Food	Quantity	Unit
Butter tea	Brewed Black tea	96	g	Tsamphuk	Water	82.2	ml
	Salt	1.5	g		Barley flour	3.5	g
	Butter	2.5	g		Chinese cabbage	13.1	g
Kapsee	Barley flour	50	g		Rape leaf	0.5	g
	Water	20	ml		Salt	0.3	g
	Cane Sugar	10	g		Butter	0.4	g
	Milk	10	g	Thukpa	Water	60	ml
	Rapeseed oil	10	g		Wheat flour	20	g
Cooked rice	Rice	28.3	g		Chinese cabbage	10	g
	Water	71.7	g		Butter	10	g
Tsampa	Barley flour	57	g		Yak meat	5	g
	Black tea	43	g				

Mineral measured values have been encoded in food files (i.e. values from Table 26 to Table 33). In order to take into account the variability of foods mineral contents, for each food, for January and for May, three sets of datas have been encoded:

- Average intake (av.) = mean values;
- Low intake (min.) = mean values minus standard deviation;
- High intake (max.) = mean values plus standard deviation.

If average value was below LOQ for a given element, no value was encoded. The same was done for really low values (e.g. some elements of brewed black tea).

In order to get an approximation of selenium intake (be it reminded that almost all Se measured values were below LOQ and even below LOD), three values by food were encoded (same values for January and May), issued from CRA-W analyses:

- The LOD value, related to the fresh matter of the food and expressed in $\mu\text{g}/100\text{g}$;
- The LOQ value, related to fresh matter of the food and expressed in $\mu\text{g}/100\text{g}$;
- The double of LOQ value related to fresh matter of the food and expressed in $\mu\text{g}/100\text{g}$.

4.2 Calculation by computing of analyzed foods' contribution to daily intake

Combining information above, daily intakes were automatically computed by the Kidmenu[®] software for each child based on his own menus. It is important to notice that daily intakes discussed below do not represent total daily intakes but represent daily intakes supplied by the foods investigated in this study. Nevertheless, foods involved in this study are the most consumed foods in term of quantities.

Because the reference table of Kidmenu[®] was not up-to-date, comparisons were made by hand with reference table issued from the *Institute of Medicine of the National Academies* (refer to chapter 5.1 Daily references intakes). This table was chosen instead of the Martin, 2000 table because it is more complete and units are more homogenous.

Results are presented from Graph 1 to Graph 14. They are expressed in percentages of recommended dietary allowances (RDA).

A red dotted line highlights the 100% RDA. A blue line or an orange line represent the upper limit (UL) which is the maximum level of daily nutrient intake that is likely to pose no risk of adverse effects. This limit varies with the age, that is why the blue line is used for children belonging to 4-8 years life stage group, and the orange line is used for 1-3 years life stage group.

In both survey, nine children on ten fulfil their phosphorus and magnesium needs. Most of them fall in the range of 100% to 250% of RDAs. The two children below the 100% line (one in January and one in May) had had a really low 24 hours food intake. Cereals and especially barley flour represent the major phosphorus and magnesium contribution.

Neither child reached the calcium 100% adequate intakes (AIs) nor even the 50%. AIs replaced RDAs in table due to a lack of data or uncertainty in data. AIs are believed to cover needs of all individuals in a given life stage and gender group. Alimentation is clearly deficient in calcium although some children consume rarely dairy products. Indeed, even with one or two glass of milk, no one of the ten children could reach its 100% AIs. Based on USDA nutritional tables, 100g of milk (whole, 3.25% milk fat, without added vitamin A and Vitamin D) could supply 113mg of calcium which could represent from 14 to 23% of RDAs (depending on the life stage group). Although calcium in dairy products is much more absorbable, a daily consumption of a glass of milk could not lead them to fulfil their needs.

Anyway, a dairy product supplementation could improve the calcium status but it could not really improve the Ca/P ratio (the milk referred above contain 84 mg P/ 100 g). An ideal Ca/P ratio ranges from 1.2 to 1.6 and it is usually equal to 0.6 in human occidental diet (Martin, 2000). In this work, the great majority of Ca/P ratios are equal to 0.1 and sometimes reach 0.3 to 0.4 (principally when the 24h food intake is low, i.e. low phosphorus intake and low calcium intake). This unbalance can cause a relative phosphorus excess resulting in hyperphosphatemia. Hyperphosphatemia disturbs calcium homeostasis (by disturbing the PTH regulation) and can cause ectopic calcifications (Martin, 2000). Another point is that significant amounts of salt are also added in diet (notably in butter tea). As seen in chapter 5.2 Calcium (Ca, AMU=40), Na excess could increase Ca urinary losses.

A Ca/Mg ratio equal to 2 is also desirable in order to prevent calcic deposits (in muscles, heart or kidneys) (Sctrick, 1991). This ratio has to be understood in term of magnesium deficiency, which seems not to be the Tibetan's case. In this work, Ca/Mg ratios are lower than 1.

Iron and copper needs are generally more than largely fulfilled. Most of children are close to the UL and some of them even exceed this UL. Bioavailability of iron decrease when a Ca/Fe ratio equal to 63 is reached. Iron absorption could decrease with a Fe/Zn ratio higher than 8 (Sctrick, 1991). It doesn't occur, Ca/Fe ratios generally range from 2 to 15 and Fe/Zn ratios are lower than 7.

Manganese intakes are not compared to RDAs but to adequate intakes (AIs, as for calcium). In no case children are below the AIs 100% line, and almost all of them are above or really close to the UL. Half of children (five in January and five in May) even ingest two or three times the upper limit value! A manganese overdose could be dangerous, blood concentration raises and induce neurotoxicity (West Suitor et al., 2006b; Martin, 2000). When Mn/Fe ratio reaches 20, troubles in iron metabolism appear in rats (Sctrick, 1991). In this case, Mn/Fe ratios never exceed 3 but iron intakes are also high.

Quantitative measures have not been possible on Selenium. Estimations of daily intakes have been done via LOD, LOQ and 2x LOQ. Taking into accounts that every sample of January was below LOQ and every sample of May was also below LOQ or even below LOD (except two samples) daily intakes are certainly overestimated (especially when 2x LOQ was encoded). In the case of the LOQ value encoded, three children in January and six children in May are around 100% of RDA. Other children are below. In the case of LOD encoded, intakes barely reached 50% of RDA. Real selenium ingestions are probably situated between average estimation (LOQ) and the low estimation (LOD), but they also could be lower.

About half of children are below or close to the RDAs 100% line for zinc, both in January and in May. Intervals between RDAs and ULs are small but only a few children are likely to reach it. Moreover, an important quantity of zinc does probably not pass through the intestinal barrier. A decrease in zinc absorption could appear in presence of a $(Ca \times \text{phytate})/Zn$ ratio higher than 0.4 (Sctrick, 1991). Now, cereals and cereal products contain phytates (Ekholm and al., 2003). A competition occurs between zinc and manganese as Mn/Zn quotient reaches 12 (Sctrick, 1991). All calculated quotients are below 3. A negative impact on zinc absorption could also arise if Fe/Zn ratio exceeds 2, but this effect is not obvious until the ratio reaches 21. All ratios of this study range from 2 to 7.

It is also important to report that iron and zinc supply by meat are much more bioavailable. Nevertheless, meat consumption is low.

On the contrary, cereals and cereal products contain antinutritional factors such as phytic acid. Phytic acid or myo-inositol hexaphosphate is a carbohydrate fibre considered as one of the most important dietary fibre components to decrease the bioavailability of minerals (Ekholm et al., 2003). According to Pointillard, 1994, from 50% to 75% of the phosphorus in vegetable is under the form of phytic acid or phytates (Na, K, Ca and Mg principally). In this organic form, phosphorus digestibility is very low. In intestines, natural phytates may dissociate into ions and phytic acid. Then, phytic acid has capacity to form high affinity complexes with other ions such as $Fe < Ca < Mn < Co < Cu < Zn$ (decreasing affinity). One mole of phytic acid bind up 3 to 6 moles of Ca. (Pointillard, 1994; Kumar and al., 2010)

Bioavailability of these elements significantly decreases because complexes are insoluble at the pH of the gastrointestinal tract (Ekholm et al., 2003; Grases and al., 2004). In a study carried out by Grases et al., 2004, effects of long term absorption of phytic acid have been evaluated on rats. Bioavailability of several elements has been estimated by comparing organs concentrations in the presence of a phytic acid free diet and a 1% sodium phytate diet. In bones, zinc concentration is significantly different between the two diets for both males and females. Magnesium concentration is also significantly different for males.

Phytate content in cereal products depends on several factors. For example, cereals ground with bran contain large amount of phytate (Harland and al., 1999). The presence of phytases (natural or microbial) could influence phytate and its derivatives levels. Phytases can hydrolyze phytic acid into several compounds (phosphate groups are removed) which have less and less chelating capacities. But phytases are thermolabile and could be destroyed by a heat treatment. (Pointillard, 1994)

Joung and al., 2004, created a phytate database for Korean foods. Similar foods to those involved in this work are listed in Table 35 below:

Table 35 Phytate content (mg/100g) of some Korean foods (Joung et al., 2004).

Food name	Phytate content mg/100g
Barley, rolled barley	350
Barley, cut polished barley	221
Wheat, medium flour	130
Potatoes, raw	55.2
Potatoes, boiled	40.6
Rice, glutinous rice, milled	160

Literature suggests that phytic acid has also beneficial health effects. Phytate has anticarcinogenic properties, working as anti-oxidant, mineral chelating agent, pH reducer, etc. There is a long list of other beneficial effects of phytate (Kumar et al., 2010). Moreover, phytate should normally not cause mineral deficiencies if essential elements are in the balanced ratio (Grases et al., 2004; Harland et al., 1999). This is not the Tibetan's case in view of their cereal based diet. They certainly ingest considerable amounts of phytates which probably bind up a part of the zinc, copper, manganese and calcium intakes (and maybe other elements). It could also decrease the digested part of zinc and calcium which make deficiencies worse, especially for calcium.

In summary:

- We confirm a marked deficiency in calcium;
 - Ca/P ratio rarely exceed 0.1;
 - Iron and copper are ingested in excess and sometimes reach upper limits;
 - Zinc intake is around 100% of RDA but absorbability is probably weak;
 - Selenium intake approximation suggests a deficiency;
 - Manganese intake often exceeds till two or three times upper limits!
-

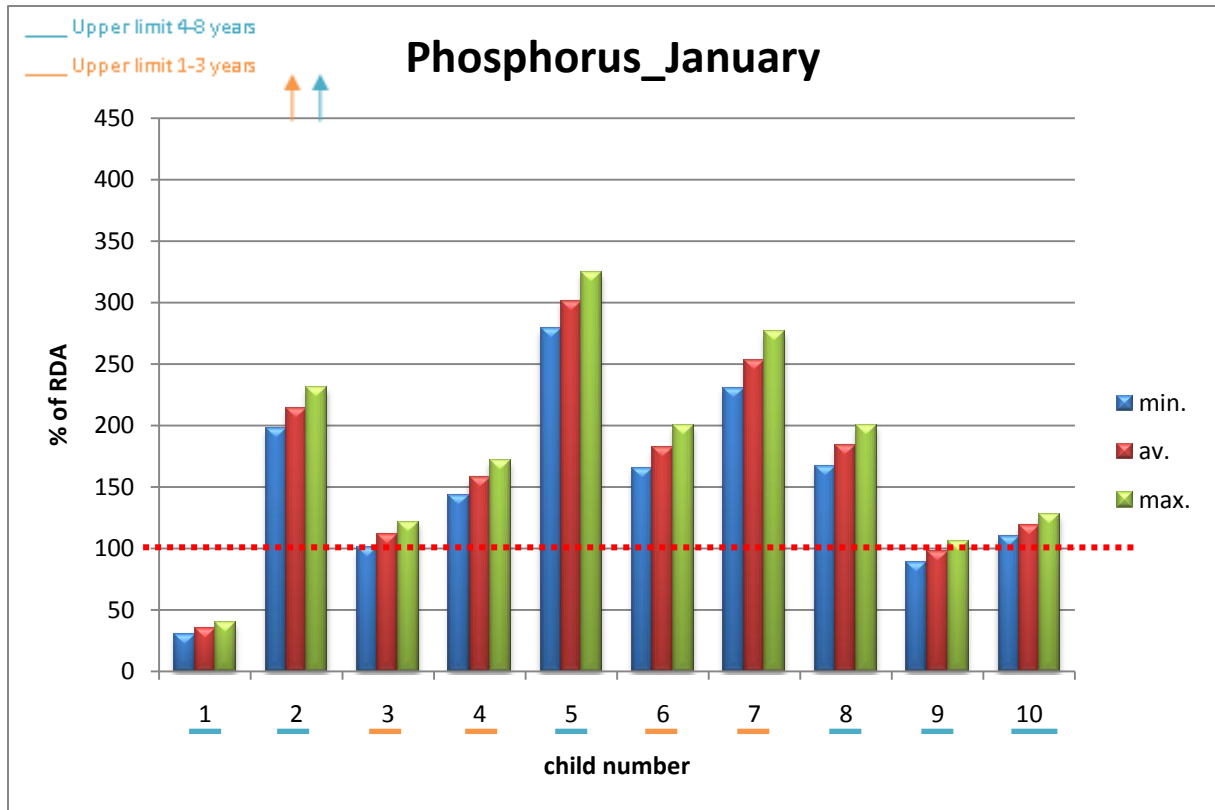

Graph 1 Phosphorus daily intake by child, expressed in % of RDA. Numbers underlined belong to life stage group: 1-3 years in orange, 4-8 years in blue, red dotted line valid for both life stage groups.

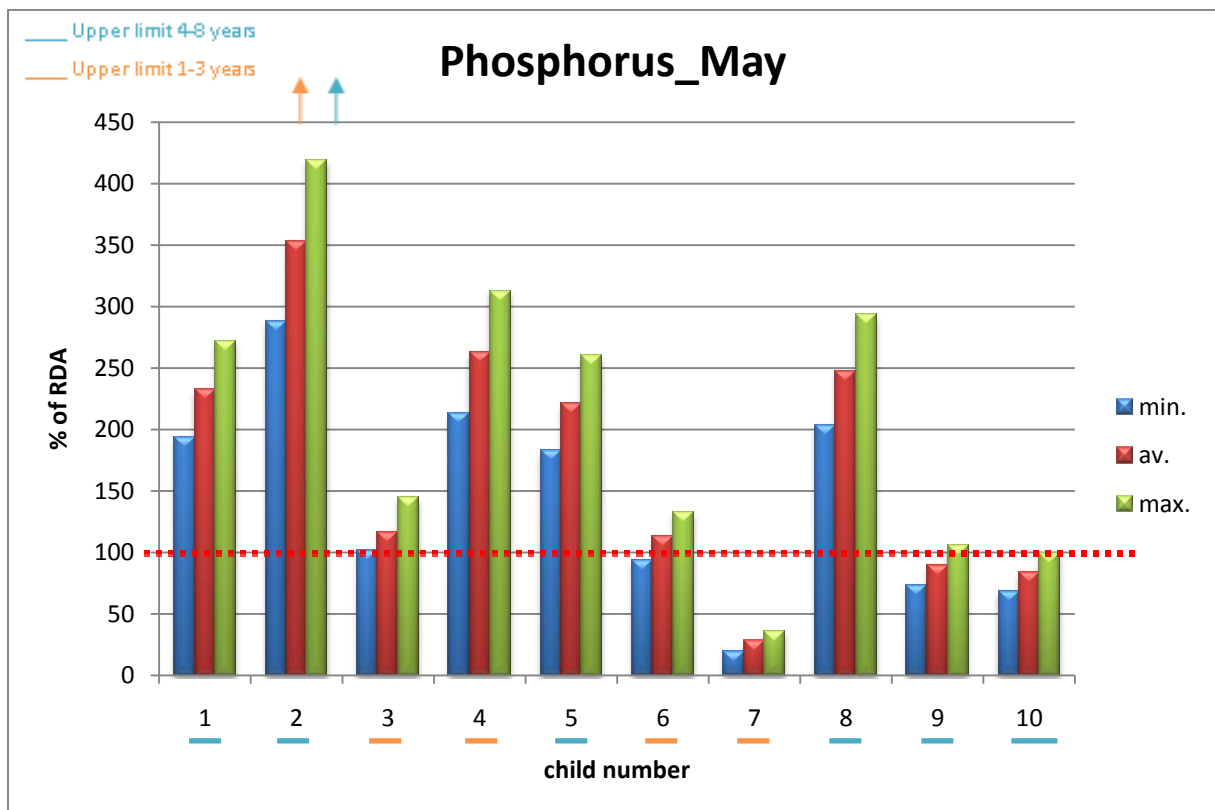

Graph 2 Phosphorus daily intake by child, expressed in % of RDA. Numbers underlined belong to life stage group: 1-3 years in orange, 4-8 years in blue, red dotted line valid for both life stage groups.

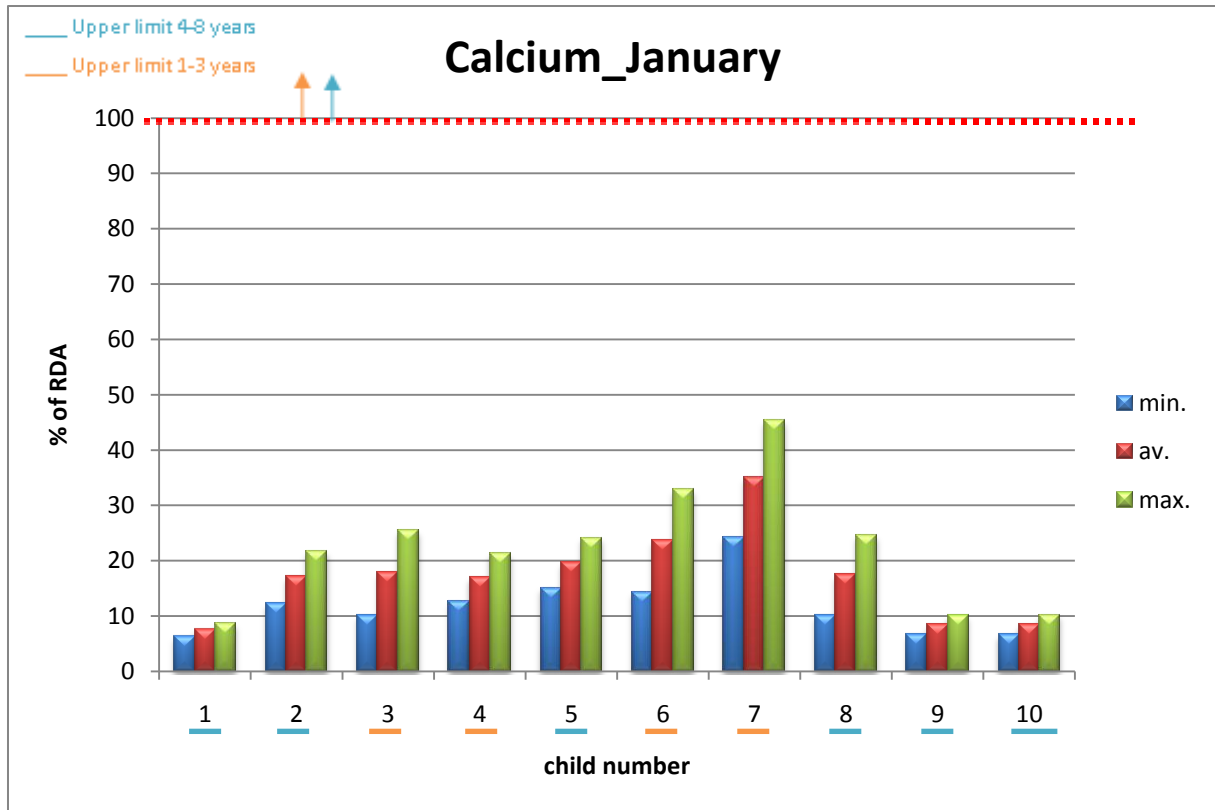

Graph 3 Calcium daily intake by child, expressed in % of RDA. Numbers underlined belong to life stage group: 1-3 years in orange, 4-8 years in blue, red dotted line valid for both life stage groups.

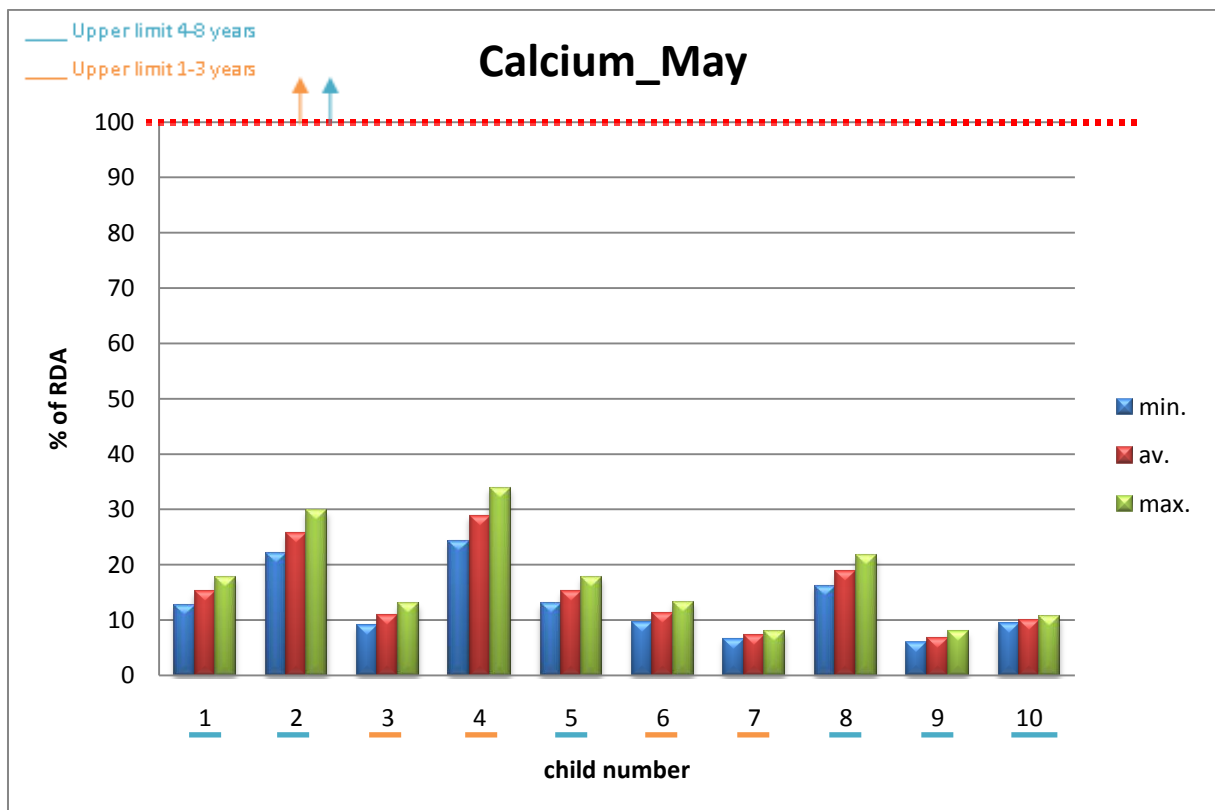

Graph 4 Calcium daily intake by child, expressed in % of RDA. Numbers underlined belong to life stage group: 1-3 years in orange, 4-8 years in blue, red dotted line valid for both life stage groups.

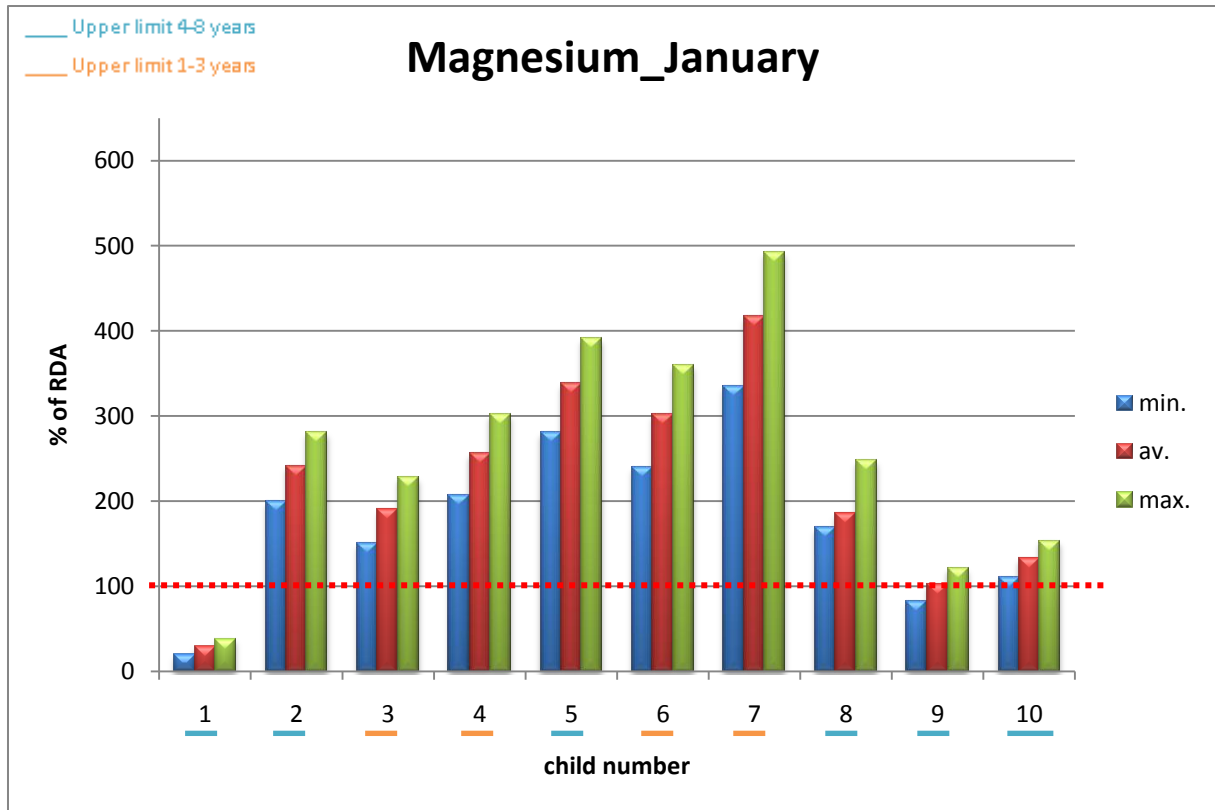

Graph 5 Magnesium daily intake by child, expressed in % of RDA. Numbers underlined belong to life stage group: 1-3 years in orange, 4-8 years in blue, red dotted line valid for both life stage groups.

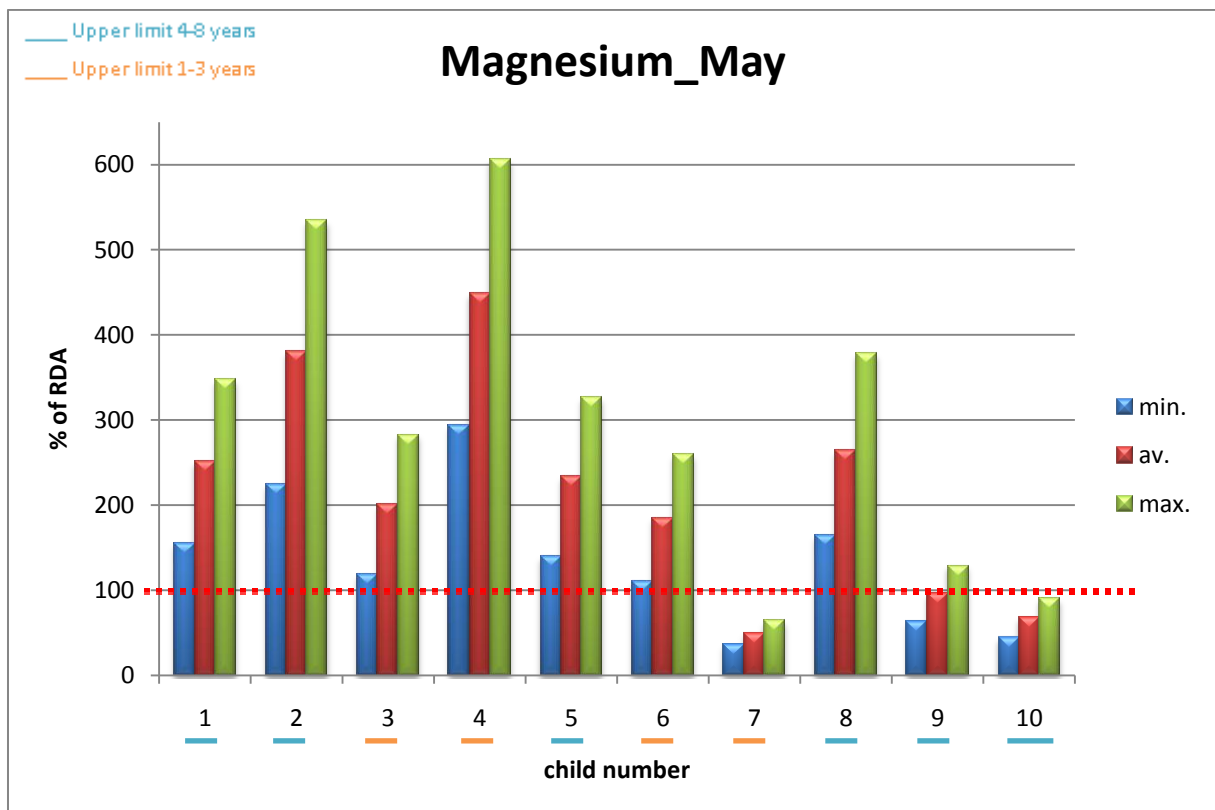

Graph 6 Magnesium daily intake by child, expressed in % of RDA. Numbers underlined belong to life stage group: 1-3 years in orange, 4-8 years in blue, red dotted line valid for both life stage groups.

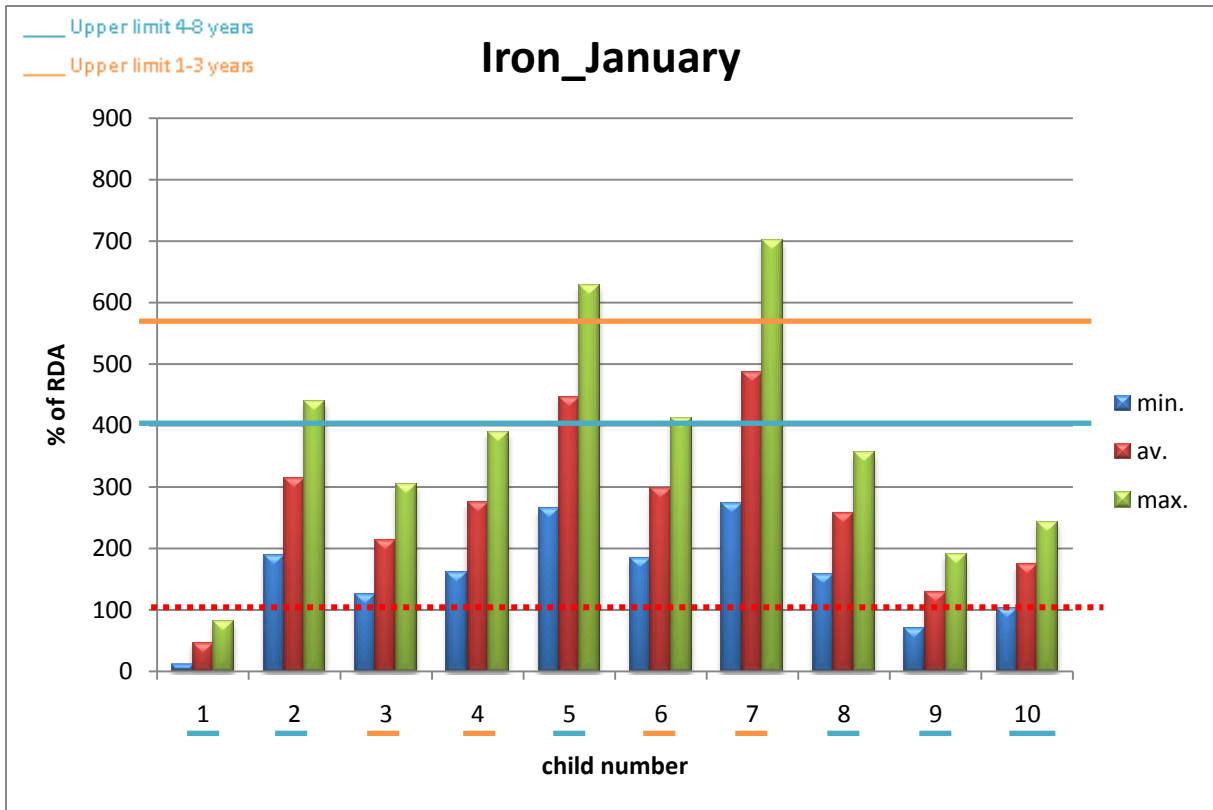

Graph 7 Iron daily intake by child, expressed in % of RDA. Numbers underlined belong to life stage group: 1-3 years in orange, 4-8 years in blue, red dotted line valid for both life stage groups.

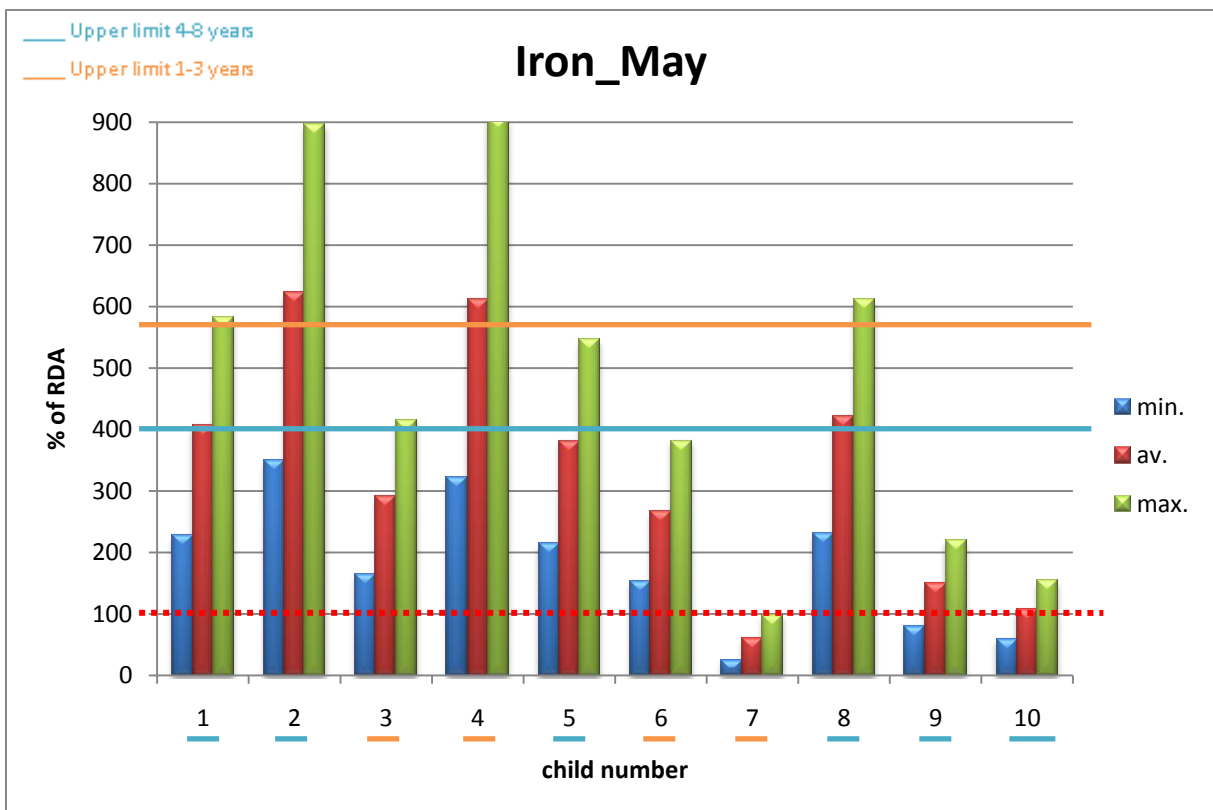

Graph 8 Iron daily intake by child, expressed in % of RDA. Numbers underlined belong to life stage group: 1-3 years in orange, 4-8 years in blue, red dotted line valid for both life stage groups.

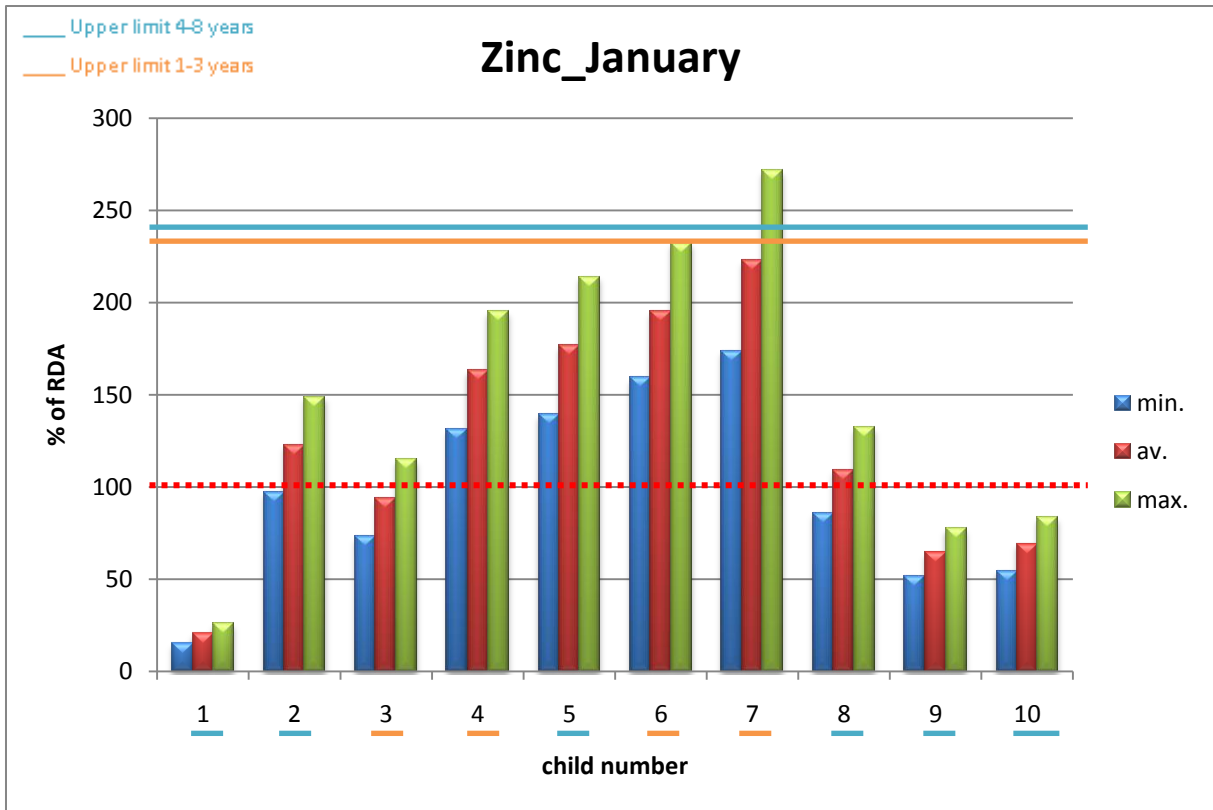

Graph 9 Zinc daily intake by child, expressed in % of RDA. Numbers underlined belong to life stage group: 1-3 years in orange, 4-8 years in blue, red dotted line valid for both life stage groups.

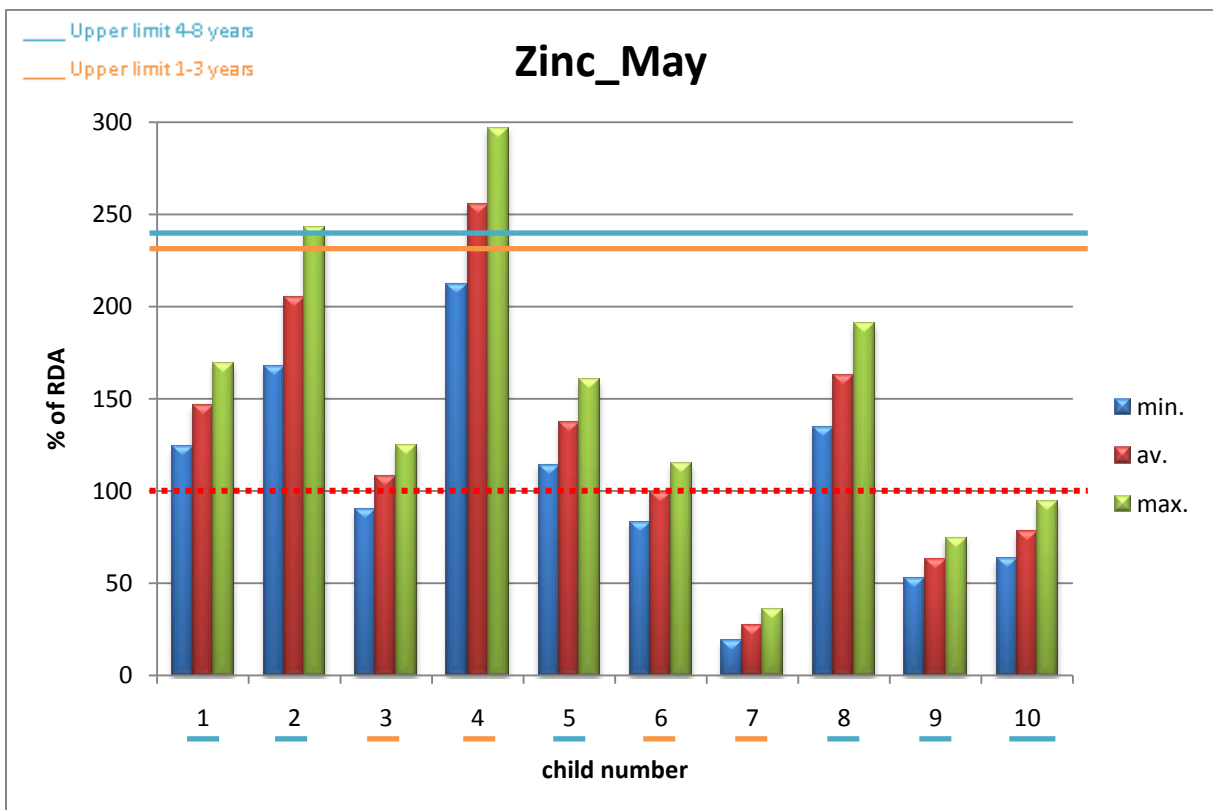

Graph 10 Zinc daily intake by child, expressed in % of RDA. Numbers underlined belong to life stage group: 1-3 years in orange, 4-8 years in blue, red dotted line valid for both life stage groups.

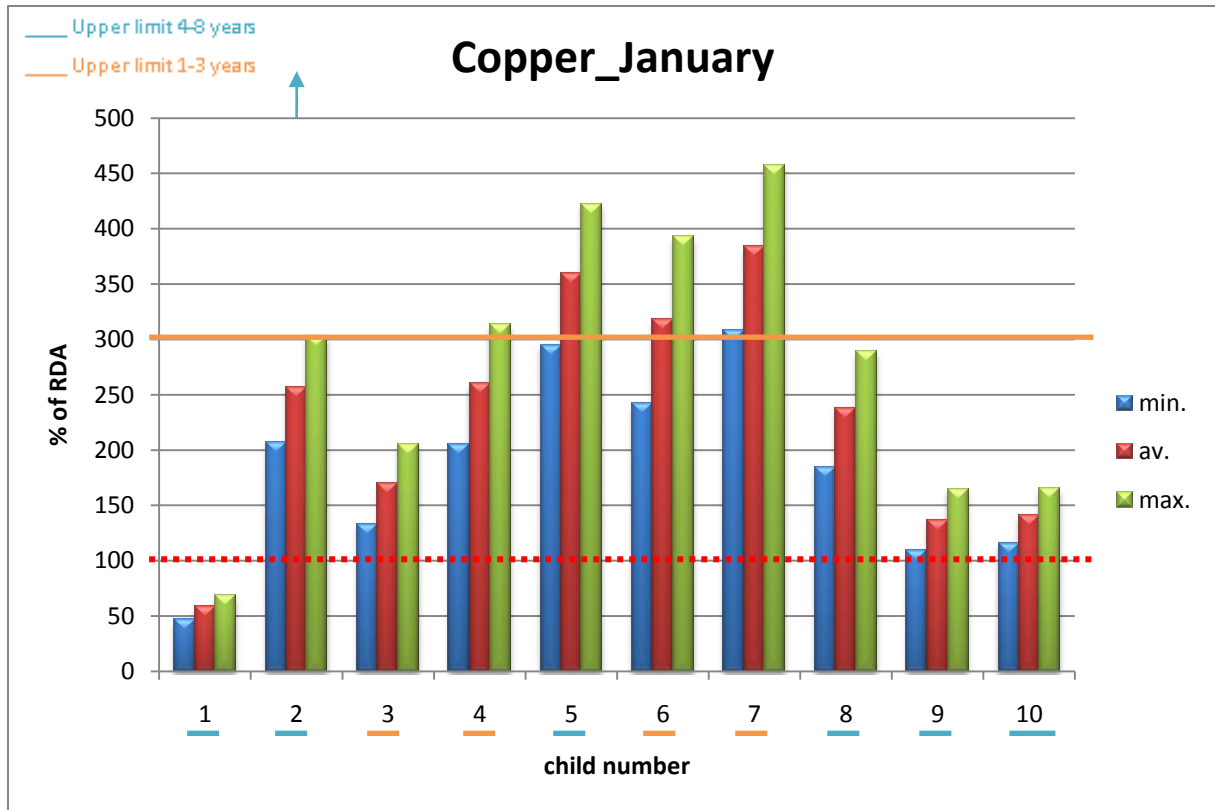

Graph 11 Copper daily intake by child, expressed in % of RDA. Numbers underlined belong to life stage group: 1-3 years in orange, 4-8 years in blue, red dotted line valid for both life stage groups.

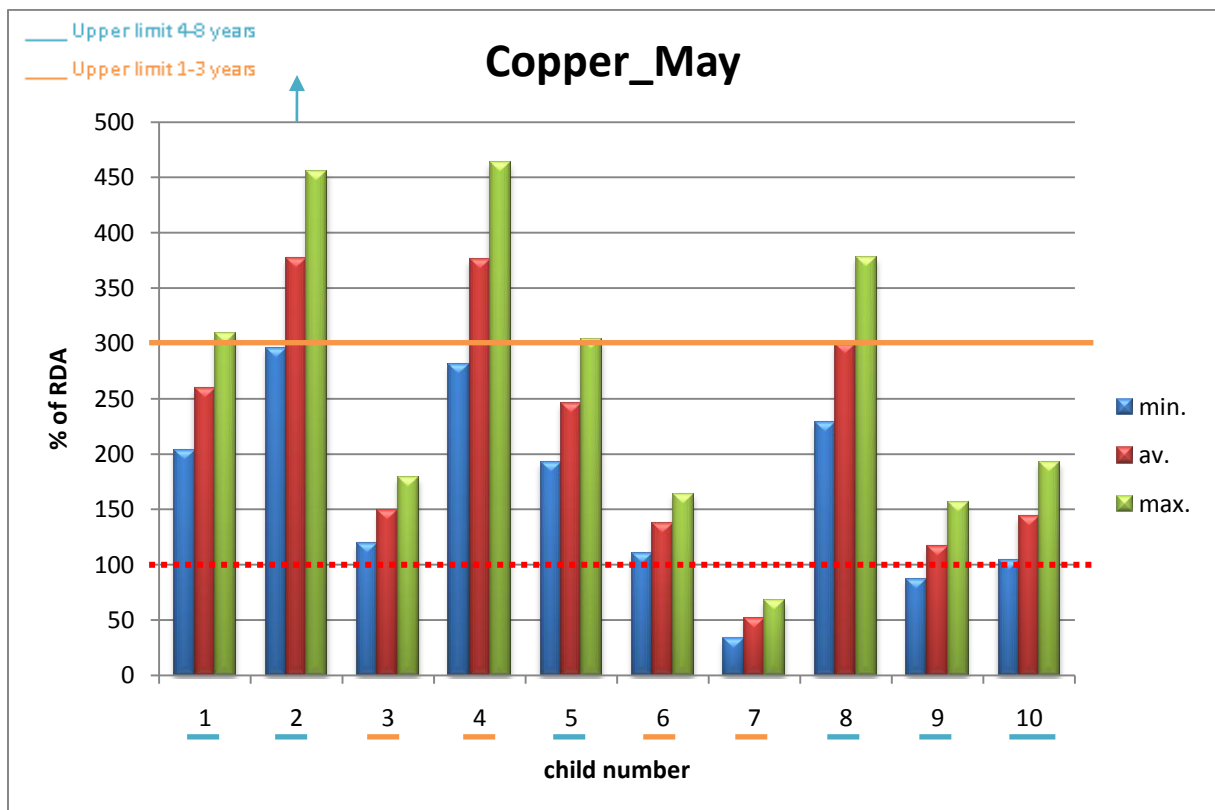

Graph 12 Copper daily intake by child, expressed in % of RDA. Numbers underlined belong to life stage group: 1-3 years in orange, 4-8 years in blue, red dotted line valid for both life stage groups.

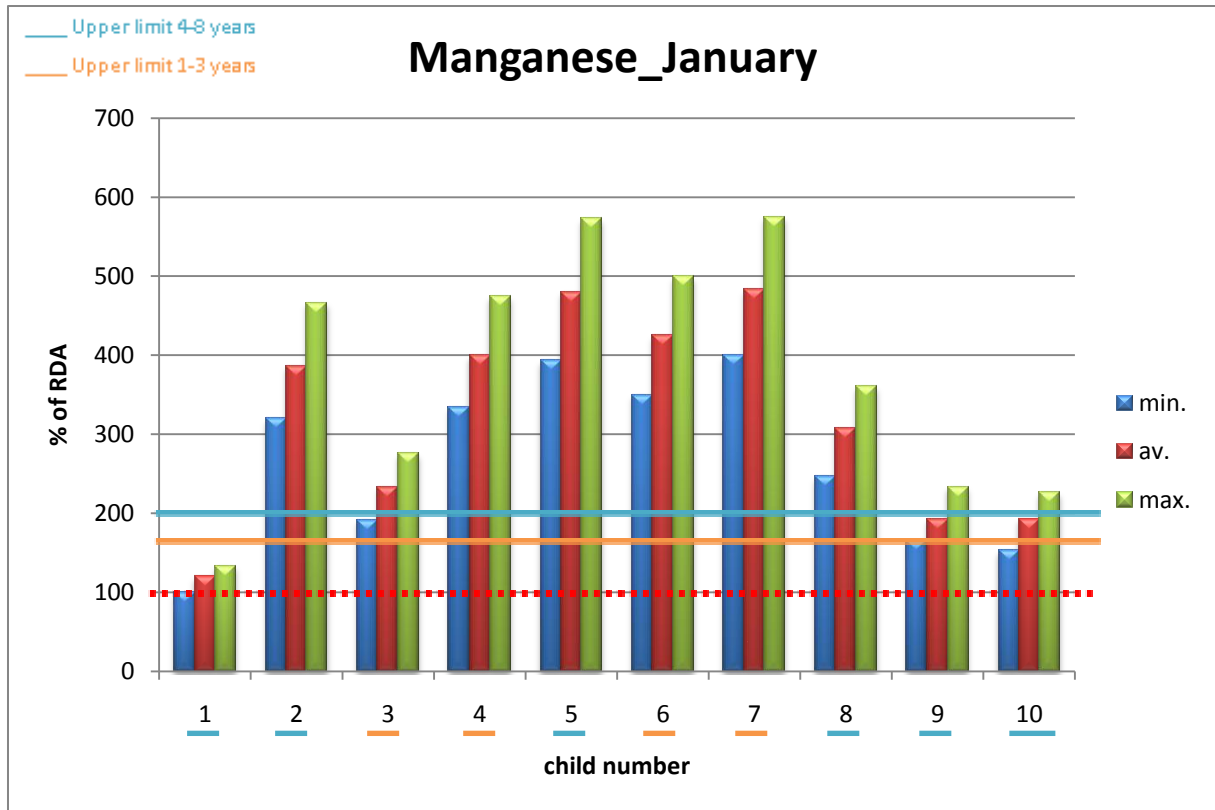

Graph 13 Manganese daily intake by child, expressed in % of RDA. Numbers underlined belong to life stage group: 1-3 years in orange, 4-8 years in blue, red dotted line valid for both life stage groups.

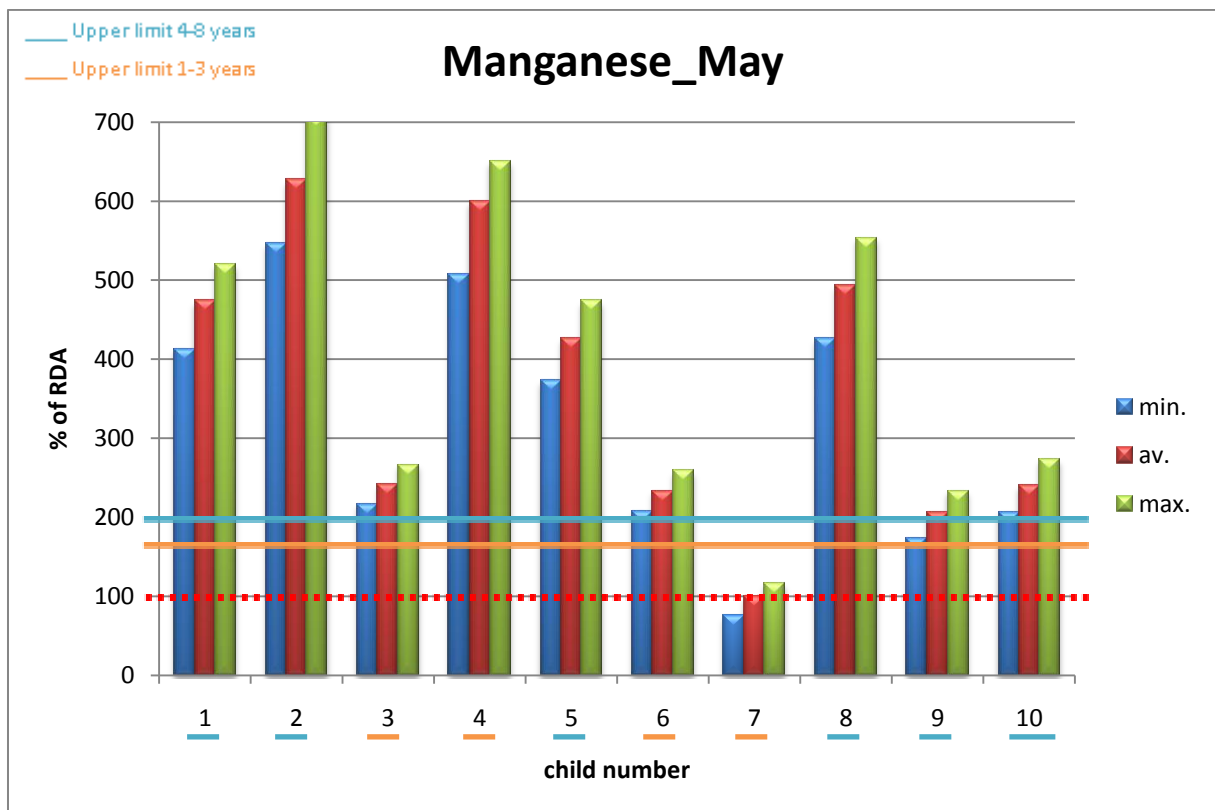

Graph 14 Manganese daily intake by child, expressed in % of RDA. Numbers underlined belong to life stage group: 1-3 years in orange, 4-8 years in blue, red dotted line valid for both life stage groups.

Conclusion and Perspectives

This work constitutes an original nutritional study in the Kashin-Beck ethiology context.

In order to meet the main objective of this study, which was to measure the mineral content of most consumed Tibetan foods, several steps had been planned.

A food sampling campaign split up into two periods and funded by the *Kashin-Beck Disease fund asbl-vzw* and *Gembloux Agro bio Tech* has been realised. It concerned ten families from two distinct regions selected according to the fore mentioned criteria (severe endemic area and presence of a 3 to 5 years child having a KBD sibling). Every family meets criteria except two families where children were 2.5 and 6.5 years old. The same families were sampled in January and in May. The sampling procedure was practical and adapted to the field conditions. Contamination risks have been limited as much as possible.

Analytical method has been optimized and validated for mineral analyses. Perishable commodities have been dried in the *Tibet Center for Disease Control and Prevention* premises (*CDC, Dir.: M.D. R. Sheero*). Mineralizations of samples have been performed by microwave assisted wet process in *Gembloux Agro Bio Tech* in the *unit of Analytical Chemistry (Head of Unit: Ph.D. G. Lognay)*. Mineral content measurements have been performed in the *Bureau Environnement et Analyse de Gembloux (BEAGx, Dir.: Ir. Ph.Maesen)*. As we have been faced to a problem with selenium and as no appropriate certified reference materials was available, this element was also analyzed in the *Walloon Agricultural Research Centre (CRA-W), Agricultural Product Technology Unit (Head of unit: Ph.D. G. Sinnaeve, Laboratory Manager: Ph.D. J-M. Romnee)*.

Validation of the analytical method consisted in certified reference materials treated in the same procedure as samples. The method has been validated for all selected elements except for strontium, arsenic and selenium. Nevertheless, Sr and As were not the most important elements involved in bone metabolism which were referred in the literature.

The repeatability of the method (mineralization + mineral measurement) was also successfully demonstrated by calculating coefficients of variation. It was expressed in percentages of relative standard deviation (%RSD). All elements for which experimental results were upper LOQ display a %RSD lower than 10% and even frequently lower than 5%.

Measured mineral food contents were compared to two food reference tables: *USDA National Nutrient Database* and *Souci Fachmann Kraut Food composition tables 1989/90*. Some significant differences have been highlighted:

- Iron content is markedly high in barley flour and black tea. It is also clearly higher than referenced values in wheat flour, potato and butter;
- Selenium content is clearly lower than referenced value in barley flour, wheat flour, rice and Chinese cabbage;
- Black tea (leaves) is rich in several elements (Ca, Fe and Mn) but brewed black tea is drunk so much diluted that mineral content is really low.

Parallel to the sampling campaign, a nutritional survey has been performed. It concerned the 24h food intake of the 3 to 5 years child. Prospective questionnaires have been distributed to the families. They were made of pictures of the principal foods. They were collected, checked and completed (translation and interpretation) with help of KBD asbl-vzw team in T.A.R.

Several observations about child's diet among families involved in the survey were highlighted:

- Total daily intake is often low in term of quantity;
- Diet is monotonous and principally based on cereals and cereal products;
- Few dishes are recurrent in every family;
- Consumption of dairy products is uncommon (except butter) and low;
- Consumption of meat and fruits is low;
- Principal beverages are brewed black tea and butter tea but some children also consume large quantities of chang (local made alcohol).

Combining the results of the nutritional survey, the food mineral contents and the recipes issued from the study of de Voghel, 2008 enabled us to estimate young Tibetans' daily intakes. It was realized via Kidmenu[®] in the *Queen Fabiola Children's University Hospital (ULB), Dietetics area (Chief Dietician: Martine Robert, Head of clinic: Pr. Ph. Goyens)*. It is important to notice that daily intakes discussed below do not represent total daily intakes but represent daily intakes supplied by the foods investigated in this study. Nevertheless, foods involved in this study represent the major part of ingested amount in term of quantities.

This estimation reveals some crucial points:

- We confirm a marked deficiency in calcium;
- Ca/P ratios rarely exceed 0.1;
- Iron and copper are ingested in excess and sometimes reach upper limits;
- Zinc intake is around 100% of RDA but absorbability is probably weak;
- Selenium intake approximation suggests a deficiency;
- Manganese intake often exceeds till two or three times upper limits!

As said before, this work presents some restrictions. Approximations have been made and some elements have not been considered. The question of the representativeness can also be discussed.

Foods mineral content were measured on 2 periods in 10 families. Even if executed in two different endemic regions, the observed tendencies cannot be extrapolated to every endemic area. Further, foods were sometimes missing in some families. Moreover, these results cannot be compared with non-endemic areas in order to highlight significant differences or not. Thus, a larger study over a longer term covering both endemic and non-endemic regions is required for definite conclusions to be reached.

The same remark is valid for the nutritional survey. A larger investigation in a more long-term could leads to more representative typical intakes. Underestimation could be avoid (in May, some children had very low intakes because parents were ploughing land all-day).

Some foods listed in the nutritional survey have been omitted in the daily intakes estimation. Some of those foods are likely to supply sizeable amounts of minerals though. One can tell *chang*, milk yak meat, *momos*, and even water. Analyze of those foods is not easy due to conditioning and transport. It would be interesting to conduct an investigation in the country.

Daily intakes values have been compared to a reference table. Dietary reference intakes can vary with the type of diet and it is important to notice that this kind of table is established for a standard population with a quite balanced diet. Yet, Tibetans may not be compared to a standard population and they do not have a balanced diet at all. As seen before, cereals and cereals based products constitute the major part of their diet. Fats and meat are consumed in low quantities. Moreover people rarely eat dairy products and fruits. Therefore, Tibetan's dietary reference intakes (DRIs) could be quite different from standard population.

Bioavailability of elements largely influences DRIs. It notably depends on the chemical speciation, on the presence of antinutritional factors (e.g. chelating agents), on the type of diet and on the individual. Taking into account those facts, it could be interesting to study the bioavailability of elements in Tibetan foods. For instance, phytate measurement on cereals and cereal products could be interesting. Bioavailability could also be evaluated by experimentations on rats fed with a Tibetan diet.

References

- Alfvén T. and al., 2004. Cadmium Exposure and Distal Forearm Fractures. *Journal of Bone and Mineral Research*, **19** (6), 900-905.
- Anaspec. *Anaspec Eurogentec Group. Basic Fibroblast Growth Factor (bFGF)*. Available online: <http://www.anaspec.com/products/productcategory.asp?id=411>, (04/08/10).
- Asagiri M. & Takayanagi H., 2007. The molecular understanding of osteoclast differentiation. *Bone*, **40** (2), 251-264.
- Baron R. & Tsouderos Y., 2002. In vitro effects of S12911-2 on osteoclast function and bone marrow macrophage differentiation. *European Journal of Pharmacology*, **450** (1), 11-17.
- Beak J. Y. and al., 2007. Krüppel-Like Zinc Finger Protein Glis3 Promotes Osteoblast Differentiation by Regulating FGF18 Expression. *Journal of Bone and Mineral Research*, **22** (8), 1234-1244.
- Brown E. M., 2003. Is the calcium receptor a molecular target for the actions of strontium on bone? *Osteoporosis International*, **14** (0), 25-34.
- Cabrera W. E. and al., 1999. Strontium and Bone. *Journal of Bone and Mineral Research*, **14** (5), 661-668.
- Chasseur C. and al. 2008a. The fungal hypothesis. In: Malaisse, F. & Mathieu, F. eds. *Big Bone Disease. A multidisciplinary approach of Kashin-Beck disease in Tibet Autonomous Region (P.R. China)*. Gembloux: Les presses agronomiques de gembloux, a.s.b.l., 85-100.
- Chasseur C. and al. 2008b. The land-ecosystem. In: Malaisse, F. & Mathieu, F. eds. *Big Bone Disease. A multidisciplinary approach of Kashin-Beck disease in Tibet Autonomous Region (P.R. China)*. Gembloux: Les presses agronomiques de gembloux, a.s.b.l., 37-48.
- Chasseur C. and al., 1997. Fungal contamination in barley and Kashin-Beck disease in Tibet. *The Lancet*, **350** (9084), 1074-1074.
- Chwan-Li S. and al., 2009. Green tea and bone metabolism. **29** (7), 437-456.
- Coqueret O. *Licence L3, Biologie cellulaire*. Available online: http://www.med.univ-angers.fr/discipline/bio_cel/LicenceUE2/LicenceUE2.html, (14/04/2010).
- Cronk J. D. *Calorimetry and enthalpy of chemical reactions*. Available online: <http://guweb2.gonzaga.edu/faculty/cronk/CHEM101pub/L17-index.cfm?L17resource=atoms02>, (13/08/10).
- de Voghel P., 2008. Valorisation nutritionnelle de l'alimentation d'enfants âgés de 9 à 16 ans, originaires de régions endémiques pour la maladie de Kashin-Beck au Tibet central. Unpublished work.

- Diplock A., 1987. Trace elements in human health with special reference to selenium. *Am J Clin Nutr*, **45** (5), 1313-1322.
- Downey C. M. and al., 2009. Osteo-Chondroprogenitor-Specific Deletion of the Selenocysteine tRNA Gene, *Trsp*, Leads to Chondronecrosis and Abnormal Skeletal Development: A Putative Model for Kashin-Beck Disease. *PLoS Genet*, **5** (8), e1000616.
- Duan C. and al., 2010. Comparative analysis of gene expression profiles between primary knee osteoarthritis and an osteoarthritis endemic to Northwestern China, Kashin-Beck disease. *Arthritis & Rheumatism*, **62** (3), 771-780.
- EFSA, 2009a. European Food Safety Agency. Scientific Opinion on Arsenic in Food. *EFSA Journal*, **7** (10).
- EFSA, 2009b. European Food Safety Agency. Cadmium in Food. *EFSA Journal*, **980**, 1-139.
- Ekholm P. and al., 2003. The effect of phytic acid and some natural chelating agents on the solubility of mineral elements in oat bran. *Food Chemistry*, **80** (2), 165-170.
- Fulcrum Health Ltd. *HUMET®*, some humifulvate science. Available online: <http://www.humet.com/acatalog/humifulvatescience.html>, (05/03/10).
- Fuller K., Kirstein B. & Chambers T. J., 2007. Regulation and enzymatic basis of bone resorption by human osteoclasts. *Clinical Science*, **112** (11), 567-575.
- Georges S. and al., 2009. Proteases and bone remodelling. *Cytokine & Growth Factor Reviews*, **20** (1), 29-41.
- Grases F. and al., 2004. Effect of phytate on element bioavailability in the second generation of rats. *Journal of Trace Elements in Medicine and Biology*, **17** (4), 229-234.
- Hadley K. B., Newman S. M. & Hunt J. R., 2010. Dietary zinc reduces osteoclast resorption activities and increases markers of osteoblast differentiation, matrix maturation, and mineralization in the long bones of growing rats. *The Journal of Nutritional Biochemistry*, **21** (4), 297-303.
- Harland B. F. & Narula G., 1999. Food phytate and its hydrolysis products. *Nutrition Research*, **19** (6), 947-961.
- Haubruge and al., 2001. The prevalence of mycotoxins in Kashin-Beck disease. *International Orthopaedics*, **25** (3), 159-161.
- Haubruge E. and al., 2000. La maladie de Kashin-Beck et le milieu rural au Tibet: un problème agri-environnemental. *Cahiers Agriculture*, **9**, 117-124.
- Heiserman D. L. *Introduction to human anatomy*. SweetHavens Publishing Services. Available online: <http://www.sweethaven.com/sweethaven/MedTech/Anatomy/coursemain.asp?whichMod=module0406>, (24/02/10).

- Henrotin Y. and al., 2001. Strontium Ranelate Increases Cartilage Matrix Formation. *Journal of Bone and Mineral Research*, **16** (2), 299-308.
- Hinsenkamp M. and al. 2008. Radiological Study. In: Malaisse, F. & Mathieu, F. eds. *Big Bone Disease. A multidisciplinary approach of Kashin-Beck disease in Tibet Autonomous Region (P.R. China)*. Gembloux: Les presses agronomiques de gembloux, a.s.b.l., 57-60.
- Holloway W. R. and al., 1996. Osteoblast-mediated effects of zinc on isolated rat osteoclasts: Inhibition of bone resorption and enhancement of osteoclast number. *Bone*, **19** (2), 137-142.
- Jacotot B. & Le Parco J.-C., 1992. *Nutrition et alimentation*. 2 éd. Paris: Masson.
- Jilka R. L. and al., 2007. Perspective: Quantifying Osteoblast and Osteocyte Apoptosis: Challenges and Rewards. *Journal of Bone and Mineral Research*, **22** (10), 1492-1501.
- Joung H. and al., 2004. Bioavailable zinc intake of Korean adults in relation to the phytate content of Korean foods. *Journal of Food Composition and Analysis*, **17** (6), 713-724.
- Kaji H. and al., 1996. High extracellular calcium stimulates osteoclast-like cell formation and bone-resorbing activity in the presence of osteoblastic cells. *Journal of Bone and Mineral Research*, **11** (7), 912-920.
- Kamura S. and al., 2010. Basic fibroblast growth factor in the bone microenvironment enhances cell motility and invasion of Ewing's sarcoma family of tumours by activating the FGFR1-PI3K-Rac1 pathway. *Br J Cancer*, **103** (3), 370-381.
- Kawai S. and al., 2007. Zinc-Finger Transcription Factor <I>Odd-Skipped Related 2</I> Is One of the Regulators in Osteoblast Proliferation and Bone Formation. *Journal of Bone and Mineral Research*, **22** (9), 1362-1372.
- Kumar V. and al., 2010. Dietary roles of phytate and phytase in human nutrition: A review. *Food Chemistry*, **120** (4), 945-959.
- Kuphaldt T. R. 2002. *Diodes and rectifiers*. Available online: http://www.faqs.org/docs/electric/Semi/SEMI_3.html, (28/04/10).
- La Grange and al., 2001. Kashin-Beck disease and drinking water in Central Tibet. *International Orthopaedics*, **25** (3), 167-169.
- Li S. and al., 2009. Soil selenium concentration and Kashin-Beck disease prevalence in Tibet, China. *Frontiers of Environmental Science & Engineering in China*, **3** (1), 62-68.
- Linsinger T. 2005. *European Reference Materials' application note 1*. Available online: http://www.erm-crm.org/html/ERM_products/application_notes/index.htm, (09/07/10).
- Ma Z. J. & Yamaguchi M., 2000. Alternation in bone components with increasing age of newborn rats: role of zinc in bone growth. *Journal of Bone and Mineral Metabolism*, **18** (5), 264-270.

Ma Z. J. & Yamaguchi M., 2001. Role of endogenous zinc in the enhancement of bone protein synthesis associated with bone growth of newborn rats. *Journal of Bone and Mineral Metabolism*, **19** (1), 38-44.

Malaisse F. and al. 2008a. Framework. *In: Malaisse, F. & Mathieu, F. eds. Big Bone Disease. A multidisciplinary approach of Kashin-Beck disease in Tibet Autonomous Region (P.R. China)*. Gembloux: Les presses agronomiques de gembloux, a.s.b.l., 19-36.

Malaisse F. and al. 2008b. The alternative food path or the very little diversified hypothesis. *In: Malaisse, F. & Mathieu, F. eds. Big Bone Disease. A multidisciplinary approach of Kashin-Beck disease in Tibet Autonomous Region (P.R. China)*. Gembloux: Les presses agronomiques de gembloux, a.s.b.l., 107-130.

Malaisse F. and al. 2008c. Protinet. *In: Malaisse, F. & Mathieu, F. eds. Big Bone Disease. A multidisciplinary approach of Kashin-Beck disease in Tibet Autonomous Region (P.R. China)*. Gembloux: Les presses agronomiques de gembloux, a.s.b.l., 131-136.

Malecki E. A. and al., 2000. Bone Structural and Mechanical Properties Are Affected by Hypotransferrinemia But Not by Iron Deficiency in Mice. *Journal of Bone and Mineral Research*, **15** (2), 271-277.

Marieb E. N., 2005. *Anatomie et physiologies humaines 6th ed*. Paris: Pearson Education limited.

Martin A., 2000. *Apports nutritionnels conseillés pour la population française. 3 éd*. Paris: Tec & Doc Editions.

Martland M. & Robison R., 1926. Possible Significance of Hexosephosphoric Esters in Ossification Part VI. Phosphoric Esters in Blood-Plasma. *Biochemical Journal*, **20** (4), 847-855.

Mathieu F. & Hinsenkamp M. 2008a. Kashin-Beck disease. *In: Malaisse, F. & Mathieu, F. eds. Big Bone Disease. A multidisciplinary approach of Kashin-Beck disease in Tibet Autonomous Region (P.R. China)*. Gembloux: Les presses agronomiques de gembloux, a.s.b.l., 11-18.

Mathieu F. and al. 2008b. Physical therapy study. *In: Malaisse, F. & Mathieu, F. eds. Big Bone Disease. A multidisciplinary approach of Kashin-Beck disease in Tibet Autonomous Region (P.R. China)*. Gembloux: Les presses agronomiques de gembloux, a.s.b.l., 61-64.

Mathieu F. and al. 2008c. Clinical Study. *In: Malaisse, F. & Mathieu, F. eds. Big Bone Disease. A multidisciplinary approach of Kashin-Beck disease in Tibet Autonomous Region (P.R. China)*. Gembloux: Les presses agronomiques de gembloux, a.s.b.l., 51-57.

Matsumoto H. and al., 1991. Superoxide dismutase and catalase activities in the growth cartilage: Relationship between oxidoreductase activity and chondrocyte maturation. *Journal of Bone and Mineral Research*, **6** (6), 569-574.

Médart J., 2009. *Manuel pratique de nutrition. L'alimentation préventive et curative. 2 éd*. Bruxelles: Editions De Boeck Université.

- Medeiros D. M. and al., 2004. Iron Deficiency Negatively Affects Vertebrae and Femurs of Rats Independently of Energy Intake and Body Weight. *J. Nutr.*, **134** (11), 3061-3067.
- Miller J. N. & Miller J. C., 2005. *Statistics and Chemometrics for Analytical Chemistry*. 5th ed. Harlow: Pearson Education Limited.
- Mizoguchi T. and al., 2005. Dolomite supplementation improves bone metabolism through modulation of calcium-regulating hormone secretion in ovariectomized rats. *Journal of Bone and Mineral Metabolism*, **23** (2), 140-146.
- Moonga B. S. & Dempster D. W., 1995. Zinc is a potent inhibitor of osteoclastic bone resorption in vitro. *Journal of Bone and Mineral Research*, **10** (3), 453-457.
- Moreno-Reyes R. and al., 2001. Selenium Deficiency-Induced Growth Retardation Is Associated with an Impaired Bone Metabolism and Osteopenia. *Journal of Bone and Mineral Research*, **16** (8), 1556-1563.
- Moreno-Reyes R. and al., 2003. Selenium and iodine supplementation of rural Tibetan children affected by Kashin-Beck osteoarthropathy. *Am. J. Clin. Nutr.*, **78** (1), 137-144.
- Mozar A. and al., 2008. High extracellular inorganic phosphate concentration inhibits RANK-RANKL signaling in osteoclast-like cells. *Journal of Cellular Physiology*, **215** (1), 47-54.
- Nadeenko V. and al., 1978. Effect of wolfram, molybdenum, copper and arsenic on intrauterine fetal development. *Farmakol Toksikol*, **41** (5), 620-623.
- Ovesen J. and al., 2001. The positive effects of zinc on skeletal strength in growing rats. *Bone*, **29** (6), 565-570.
- Peng A. & Xu L., 1987. Antagonism between selenium and humic acid. *Sci. Sin. B.*, **30** (1), 66-74.
- Pettifor J. M. & Moodley G. P., 1997. Appendicular Bone Mass in Children with a High Prevalence of Low Dietary Calcium Intakes. *Journal of Bone and Mineral Research*, **12** (11), 1824-1832.
- Pi M. & Quarles L. D., 2004. A Novel Cation-Sensing Mechanism in Osteoblasts Is a Molecular Target for Strontium. *Journal of Bone and Mineral Research*, **19** (5), 862-869.
- Pinta M. & Riandey C. 1968. *Les effets de matrice sur le dosage des traces par absorption atomique*. Available online: http://horizon.documentation.ird.fr/exl-doc/pleins_textes/pleins_textes_5/b_fdi_12-13/14107.pdf, (28/07/10).
- Pointillard A., 1994. Phytates, phytases : leur importance dans l'alimentation des monogastriques. *INRA Prod. Anim.*, **7** (1), 29-39.
- Pradayrol L., 1999. TGF- β : voies de signalisation et gènes suppresseurs de tumeurs = TGF- β : signal transduction pathways and tumor suppressor genes. *Hématologie*, **5** (6), 451-459.

- Rousselle A. V. & Heymann D., 2002. Osteoclastic acidification pathways during bone resorption. *Bone*, **30** (4), 533-540.
- Sarazin M., Alexandre C. & Thomas T., 2000. Influence des apports en oligoéléments, protéines, lipides, glucides et vitamines sur le métabolisme osseux Influence of trace element, protein, lipid, carbohydrate, and vitamin intakes on bone metabolism. *Revue du Rhumatisme*, **67** (7), 486-497.
- Schlüter K. D. 1999. PTH and PTHrP: Similar Structures but Different Functions. *News Physiol Sci* [Online], 14. Available: <http://physiologyonline.physiology.org/cgi/content/full/14/6/243#SEC5>, (14/04/2010).
- Sctrick L., 1991. *L'oligothérapie exactement*. Limoges: Editions Roger Jollois.
- Seco C. and al., 1998. Effects of Zinc Supplementation on Vertebral and Femoral Bone Mass in Rats on Strenuous Treadmill Training Exercise. *Journal of Bone and Mineral Research*, **13** (3), 508-512.
- Shi X.-w. and al., 2008. Familial aggregation and sibling heritability in Kashin-Beck disease. *Journal of Southern Medical University*, **28** (7), 1187-1189.
- Shi Z. and al., 2009. Butenolide induced cytotoxicity by disturbing the prooxidant-antioxidant balance, and antioxidants partly quench in human chondrocytes. *Toxicology in Vitro*, **23** (1), 99-104.
- Skoog D. A., Holler F. J. & Grouch S. R., 2008. *Principles of Instrumental Analysis*. 6th ed. Farmington Hills: Thomson Brooks/Cole.
- Souci S. W., Fachmann W. & Kraut H., 1989/90. *Food Composition and Nutrition Tables*. 4th revised and completed edition. Stuttgart: Wissenschaftliche Verlagsgesellschaft mbH.
- Suetens and al., 2001. Epidemiological support for a multifactorial aetiology of Kashin-Beck disease in Tibet. *International Orthopaedics*, **25** (3), 180-187.
- Takahashi N. and al., 2003. S 12911-2 Inhibits Osteoclastic Bone Resorption In Vitro. *Journal of Bone and Mineral Research*, **18** (6), 1082-1087.
- Tan J. a. and al., 2002. Selenium in soil and endemic diseases in China. *The Science of The Total Environment*, **284** (1-3), 227-235.
- Tapiero H., Townsend D. M. & Tew K. D., 2003. The antioxidant role of selenium and seleno-compounds. *Biomedicine & Pharmacotherapy*, **57** (3-4), 134-144.
- Thomas R., 2008. *Practical guide to ICP-MS A tutorial for Beginners*. 2d ed. Oxford: CRC Press, Taylor & Francis Group.
- Tsumaki N. and al., 2002. Bone Morphogenetic Protein Signals Are Required for Cartilage Formation and Differently Regulate Joint Development During Skeletogenesis. *Journal of Bone and Mineral Research*, **17** (5), 898-906.

UNESCAP. *United nations Economic and Social Commission for Asia and the Pacific, Tibet*. Available online: <http://www.unescap.org/esid/psis/population/database/chinadata/tibet.htm>, (20/02/2010).

University Of California D. o. C. Available online: http://chemwiki.ucdavis.edu/Analytical_Chemistry/Instrumental_Analysis/Spectrometer, (27/04/2010).

US Departement of Agriculture, 2010. *USDA National Nutrient Database for Standard Reference*. Available online: http://www.ars.usda.gov/main/site_main.htm?modecode=12-35-45-00 (14/07/10).

Vyskocil A. & Viau C., 1999. Assessment of molybdenum toxicity in humans. *Journal of Applied Toxicology*, **19** (3), 185-192.

Wang H. and al., 2003. Influence of Environmental Cadmium Exposure on Forearm Bone Density. *Journal of Bone and Mineral Research*, **18** (3), 553-560.

Wang S. and al., 2008. Detection of serum proteomic changes and discovery of serum biomarkers for Kashin-Beck disease using surface-enhanced laser desorption ionization mass spectrometry (SELDI-TOF MS). *Journal of Bone and Mineral Metabolism*, **26** (4), 385-393.

Wang W. Z. and al., 2009. Comparative analysis of gene expression profiles between the normal human cartilage and the one with endemic osteoarthritis. *Osteoarthritis and Cartilage*, **17** (1), 83-90.

Wangla R. 2010, personal communication.

Welz B. & Sperling M., 1999. *Atomic Absorption Spectrometry*. 3rd, completely revised edition. Hoboken: WILEY-VCH.

West Suitor C. & Meyers L. D. 2006a. *Dietary Reference Intakes Research Synthesis: Workshop Summary*. Washington: National Academies Press. Available online: <http://www.iom.edu/Global/News%20Announcements/~media/Files/Activity%20Files/Nutrition/DRIs/DRISummaryListing2.ashx> (05/07/10).

West Suitor C. & Meyers L. D. 2006b. *Dietary Reference Intakes Research Synthesis: Workshop Summary*. Washington: National Academies Press. Available online: <http://www.iom.edu/Global/News%20Announcements/~media/48FAAA2FD9E74D95BBD A2236E7387B49.ashx> (05/07/10).

Yang C. and al., 1993. Selenium deficiency and fulvic acid supplementation induces fibrosis of cartilage and disturbs subchondral ossification in knee joints of mice: An animal model study of Kashin-Beck disease. *Virchows Archiv*, **423** (6), 483-491.

Yao Y.-f. and al., 2010. Study on the effect of T-2 toxin combined with low nutrition diet on rat epiphyseal plate growth and development. *International Orthopaedics*, 1-6.

Yost & Daunt. *Atomoc Absorption and Emission Spectra*. Available online: <http://csep10.phys.utk.edu/astr162/lect/light/absorption.html>, (22/04/10).

Zarjou A. and al., 2010. Ferritin ferroxidase activity: A potent inhibitor of osteogenesis. *Journal of Bone and Mineral Research*, **25** (1), 164-172.

Zhu G. and al., 2004. Environmental cadmium exposure and forearm bone density. *BioMetals*, **17** (5), 499-503.

Appendix



Picture 1 The urban zone, Lhasa (T.A.R., 2010).



Picture 2 The urban zone, Lhasa street (T.A.R., 2010).



Picture 3 The suburban zone around Lhasa (T.A.R., 2010).



Picture 4 The suburban zone around Lhasa (T.A.R., 2010).



Picture 5 The agricultural zone (T.A.R., 2010).



Picture 6 The agricultural zone, a man ploughing the land (Nimo county, T.A.R., 2010)



Picture 7 The choice of families (T.A.R., 2010).



Picture 8 Foods sampling (T.A.R., 2010)

















Nutritional questionnaire		volume of the standard bowl:	
date of the questionnaire	village	Chid identity	Date of birth and sex
tsampa (standard bowl)	butter tea (standard bowl)	black tea (standard bowl)	momo (standard pieces)
			
potatos (standard pieces)	rice (standard bowl)	cheese (standard pieces)	fruits (number)
			
chang (standard bowl)	Roasted barley (handfull)	Candies (number)	
			
Cooking pot (standard bowl)	 meat (standard pieces)	 vegetables	 beans
		 noodles	 potatos

Figure 25 The food questionnaire used in nutritional surveys.



Picture 9 Electrothermal atomic absorption spectrometer (BEAGx).

Table 1 Foods mineral contents (mg/kg MS), samples of January.

mg/kg MS	P	Ca	Mg	Fe	Zn	Cu
Barley flour 49_1	4410	281	941	139	20	4.4
Barley flour 45_2	4100	212	714	84	12	4.3
Barley flour 66_3	4299	374	1283	130	26	2.9
Barley flour 2_4	4052	408	1339	130	29	4.5
Barley flour 22_5	4070	348	1248	60	26	3.3
Barley flour 742_6	4023	421	1293	231	27	4.9
Barley flour 568_7	3942	450	1242	139	28	4.7
Barley flour 860_8	3873	454	1207	66	22	3.4
Barley flour 636_9	3737	500	1156	112	21	5.0
Barley flour 703_10	3277	513	1132	91	23	4.7
Black tea 49_1	1759	3868	1421	282	21	11.2
Black tea 45_2	2700	6162	1902	536	31	23.1
Black Tea 66_3	2084	10436	2979	2354	38	41.0
Black Tea 2_4	2003	8689	2303	1381	32	12.4
Black Tea 22_5	2459	9079	2642	527	30	11.2
Black Tea 746_6	2215	9204	2642	514	29	11.1
Black Tea 568_7	2386	8975	2628	731	33	11.6
Black Tea 860_8	2322	9799	2888	754	36	14.1
Black Tea 636_9	2063	9888	2213	747	33	11.7
Black Tea 703_10	2372	8370	2424	531	31	20.3
Wheat 49_1	1319	189	223	16	7	2.3
Wheat 45_2	1166	126	157	21	5	2.8
Wheat 66_3	1299	300	369	25	10	2.3
Wheat 2_4	943	313	207	13	7	1.3
Wheat 22_5	1174	323	294	23	9	2.0
Wheat 746_6	1670	282	404	76	11	2.2
Wheat 568_7	1475	369	462	97	11	2.4
Wheat 636_9	1327	335	304	47	9	1.7
Wheat 703_10	4016	737	1259	63	29	10.5
Potatoes 49_1	3781	295	782	85	9	3.3
Potatoes 66_3	3913	302	780	64	11	4.6
Potatoes 746_6	2650	707	1241	110	12	2.5
Potatoes 568_7	2213	198	1132	63	10	4.2
Potatoes 860_8	2121	313	1089	94	9	4.5
Potatoes 636_9	2014	349	750	72	5	1.4
Potatoes 703_10	2925	268	1090	71	12	3.3
Rice 49_1	1025	69	217	6	16	3.0
Rice 2_4	1400	80	399	9	12	3.4
Rice 22_5	1093	99	231	8	16	2.1
Rice 746_6	1067	75	226	7	16	2.3
Rice 568_7	1085	76	207	5	14	1.4
Rice 636_9	1265	83	287	5	18	3.0
Butter 746_6	<200	180	<20	1	<1.5	<0.5
Butter 636_9	215	197	<20	4	<1.5	<0.5
Chinese cabbage 9	9031	8622	1605	70	36	6.8
Chinese cabbage 10	8723	6425	1267	67	31	7.6

Table 2 Foods mineral contents (mg/kg MS), samples of January.

mg/kg MS	Mn	Se	Ni	Sr	Mo	As	Cd
Barley flour 49_1	13	<0.1	<5	<55	<15	0.07	<0.01
Barley flour 45_2	12	<0.1	<5	<55	<15	<0.05	<0.01
Barley flour 66_3	21	<0.1	<5	<55	<15	0.11	<0.01
Barley flour 2_4	20	<0.1	<5	<55	<15	0.10	0.02
Barley flour 22_5	15	<0.1	<5	<55	<15	<0.05	0.02
Barley flour 742_6	22	<0.1	<5	<55	<15	<0.05	<0.01
Barley flour 568_7	19	<0.1	<5	<55	<15	0.06	<0.01
Barley flour 860_8	16	<0.1	<5	<55	<15	<0.05	<0.01
Barley flour 636_9	19	<0.1	<5	<55	<15	0.12	0.05
Barley flour 703_10	18	<0.1	<5	<55	<15	0.08	0.05
Black tea 49_1	1164	<0.1	10	<55	<15	<0.05	/
Black tea 45_2	1775	0.2	115	89	<15	0.34	/
Black Tea 66_3	1999	0.2	12	<55	<15	0.27	0.22
Black Tea 2_4	1880	0.4	10	<55	<15	0.92	0.20
Black Tea 22_5	2238	<0.1	10	<55	<15	0.56	0.19
Black Tea 746_6	2132	0.2	9	<55	<15	0.65	0.18
Black Tea 568_7	1838	0.2	11	<55	<15	0.67	0.20
Black Tea 860_8	1948	0.2	12	<55	<15	0.75	0.23
Black Tea 636_9	1992	0.2	8	<55	<15	0.64	0.27
Black Tea 703_10	1929	<0.1	10	<55	<15	0.51	0.18
Wheat 49_1	8.7	<0.1	<5	<55	<15	<0.05	/
Wheat 45_2	10.9	<0.1	<5	<55	<15	<0.05	/
Wheat 66_3	11.6	<0.1	<5	<55	<15	<0.05	0.03
Wheat 2_4	<7.5	<0.1	<5	<55	<15	<0.05	0.01
Wheat 22_5	9.9	<0.1	<5	<55	<15	<0.05	0.02
Wheat 746_6	10.5	<0.1	<5	<55	<15	<0.05	<0.01
Wheat 568_7	9.9	<0.1	<5	<55	<15	0.05	0.01
Wheat 636_9	8.7	<0.1	<5	<55	<15	<0.05	<0.01
Wheat 703_10	22.5	<0.1	<5	<55	<15	<0.05	0.01
Potatoes 49_1	10	<0.1	<5	<55	<15	<0.05	/
Potatoes 66_3	<7.5	<0.1	<5	<55	<15	<0.05	/
Potatoes 746_6	12	<0.1	<5	<55	<15	<0.05	0.01
Potatoes 568_7	7.99	<0.1	<5	<55	<15	<0.05	0.01
Potatoes 860_8	<7.5	<0.1	<5	<55	<15	<0.05	<0.01
Potatoes 636_9	<7.5	<0.1	<5	<55	<15	0.06	0.02
Potatoes 703_10	11	<0.1	<5	<55	<15	0.06	0.02
Rice 49_1	10.1	<0.1	<5	<55	<15	0.06	/
Rice 2_4	9.9	<0.1	<5	<55	<15	<0.05	/
Rice 22_5	12.9	<0.1	<5	<55	<15	0.11	0.16
Rice 746_6	11.2	<0.1	<5	<55	<15	0.14	0.08
Rice 568_7	9.2	<0.1	<5	<55	<15	0.11	0.05
Rice 636_9	11.5	<0.1	<5	<55	<15	0.12	0.29
Butter 746_6	<7.5	<0.1	<5	<55	<15	<0.05	/
Butter 636_9	<7.5	<0.1	<5	<55	<15	<0.05	/
Chinese cabbage 9	29	<0.1	<5	93	<15	<0.05	/
Chinese cabbage 10	24	<0.1	<5	87	<15	<0.05	/

Table 3 Foods mineral contents (mg/kg MS), samples of May.

mg/kg MS	P	Ca	Mg	Fe	Zn	Cu
Barley flour 49_1	4412	428	1083	111	21	2.60
Barley flour 45_2	4512	365	1110	88	25	3.48
Barley flour 66_3	4591	264	1122	258	26	3.08
Barley flour 2_4	4500	324	1129	191	29	4.86
Barley flour 22_5	4595	329	1082	123	25	3.16
Barley flour 742_6	4506	364	1113	242	28	4.51
Barley flour 568_7	2768	463	642	153	20	4.20
Barley flour 860_8	4048	402	1230	82	21	3.44
Barley flour 636_9	4111	481	2384	105	20	3.34
Barley flour 703_10	2787	478	689	110	18	3.99
Black tea 49_1	2024	7782	1953	827	36	13.53
Black tea 45_2	1909	6606	2307	575	33	18.51
Black Tea 66_3	2103	6316	2026	875	35	16.90
Black Tea 2_4	1944	6755	1850	733	36	12.51
Black Tea 22_5	2184	9080	2022	851	37	13.38
Black Tea 746_6	2300	7093	2143	912	35	13.78
Black Tea 568_7	2415	6789	2246	606	30	16.24
Black Tea 860_8	1948	6748	2226	819	33	13.85
Black Tea 636_9	1997	6938	2081	764	39	14.10
Wheat 49_1	1183	247	243	33	8	1.77
Wheat 45_2	1381	282	317	33	11	2.24
Wheat 66_3	1484	292	357	40	9	3.60
Wheat 2_4	964	268	189	25	7	1.41
Wheat 22_5	1373	308	303	31	9	1.80
Wheat 746_6	1694	248	365	88	11	2.21
Wheat 568_7	2079	307	567	103	14	2.79
Wheat 636_9	2053	337	539	41	18	3.20
Wheat 703_10	2718	310	767	53	19	3.34
Potatoes 49_1	3708	660	1438	53	18	1.76
Potatoes 45_2	2234	388	1179	86	14	2.98
Potatoes 66_3	3584	582	1503	55	16	2.07
Potatoes 22_5	2811	581	1055	69	15	4.15
Potatoes 746_6	3005	448	1285	254	13	5.83
Potatoes 568_7	2314	245	1320	123	10	4.93
Potatoes 860_8	1350	513	976	207	9	2.69
Potatoes 636_9	1051	549	1209	70	10	2.87
Potatoes 703_10	1620	528	1258	52	16	4.26
Rice 49_1	1193	99	285	47	13	2.27
Rice 45_2	1216	88	251	24	14	2.46
Rice 2_4	1280	92	269	26	12	1.99
Rice 22_5	1105	73	177	22	15	1.47
Rice 568_7	1144	72	177	18	16	2.00
Rice 860_8	1031	78	197	24	12	2.20
Rice 636_9	1048	74	168	17	13	0.90
Rice 703_10	966	64	146	18	15	2.24
Chinese cabbage	11818	11426	2596	359	63	6.54

Table 4 Foods mineral contents (mg/kg MS), samples of May.

mg/kg MS	Mn	Ni	Sr	Mo	As	Cd
Barley flour 49_1	17	0.6	<8.8	<15	0.08	<0.05
Barley flour 45_2	18	0.5	<8.8	<15	0.05	<0.05
Barley flour 66_3	17	0.6	<8.8	<15	0.17	<0.05
Barley flour 2_4	20	<0.41	<8.8	<15	0.08	<0.05
Barley flour 22_5	16	<0.41	<8.8	<15	0.04	<0.05
Barley flour 742_6	21	<0.41	11	<15	0.06	<0.05
Barley flour 568_7	19	<0.41	10	<15	0.05	<0.05
Barley flour 860_8	16	<0.41	10	<15	0.03	<0.05
Barley flour 636_9	19	<0.41	11	<15	0.25	<0.05
Barley flour 703_10	19	<0.41	11	<15	0.12	<0.05
Black tea 49_1	1920	8.7	19	<15	0.852	0.40
Black tea 45_2	1728	10.3	14	<15	0.716	0.41
Black Tea 66_3	1801	8.6	15	<15	0.603	0.18
Black Tea 2_4	2004	7.8	16	<15	0.523	0.40
Black Tea 22_5	2234	8.8	23	<15	0.644	0.36
Black Tea 746_6	1826	9.2	16	<15	0.751	0.23
Black Tea 568_7	1661	8.5	17	<15	0.508	0.16
Black Tea 860_8	1372	7.3	18	<15	0.733	0.21
Black Tea 636_9	1583	9.0	17	<15	0.691	0.22
Wheat 49_1	10	<0.41	11	<15	<0.02	0.09
Wheat 45_2	9	0.7	12	<15	<0.02	<0.05
Wheat 66_3	13	0.5	13	<15	<0.02	<0.05
Wheat 2_4	7	<0.41	14	<15	<0.02	<0.05
Wheat 22_5	13	<0.41	13	<15	<0.02	<0.05
Wheat 746_6	10	<0.41	12	<15	0.03	<0.05
Wheat 568_7	10	<0.41	13	<15	0.06	<0.05
Wheat 636_9	12	<0.41	13	<15	<0.02	<0.05
Wheat 703_10	17	<0.41	13	<15	0.05	<0.05
Potatoes 49_1	9	<0.41	12	<15	0.02	<0.05
Potatoes 45_2	11	0.92	<8.8	<15	0.09	0.10
Potatoes 66_3	9	0.42	<8.8	<15	<0.02	<0.05
Potatoes 22_5	8	0.61	<8.8	<15	0.03	0.07
Potatoes 746_6	10	0.60	<8.8	<15	0.03	<0.05
Potatoes 568_7	9	0.42	<8.8	<15	0.02	<0.05
Potatoes 860_8	9	0.86	<8.8	<15	<0.02	<0.05
Potatoes 636_9	8	<0.41	<8.8	<15	<0.02	<0.05
Potatoes 703_10	13	1.6	<8.8	<15	<0.02	<0.05
Rice 49_1	11	<0.41	<8.8	<15	0.082	<0.05
Rice 45_2	10	0.8	<8.8	<15	0.083	0.10
Rice 2_4	11	0.5	<8.8	<15	0.088	<0.05
Rice 22_5	13	<0.41	<8.8	<15	0.087	0.05
Rice 568_7	13	<0.41	<8.8	<15	0.076	0.16
Rice 860_8	12	<0.41	<8.8	<15	0.085	<0.05
Rice 636_9	12	<0.41	<8.8	<15	0.094	<0.05
Rice 703_10	12	<0.41	<8.8	<15	0.075	0.16
Chinese cabbage 9	43	1.5	20	<15	<0.02	0.09

Table 5 Selenium analyses (CRA-W) on samples of May, expressed in µg/l of mineralized solution.

Selenium	µg/l	LOD = 0.33µg/l; LOQ = 1µg/l
Blanco R6'	0.26	<LOD
blanco 21/05	0.35	LOD < X < LOQ
Barley flour 49_1	1.96	
Barley flour 45_2	0.35	LOD < X < LOQ
Barley flour 66_3	0.00	<LOD
Barley flour 2_4	0.55	LOD < X < LOQ
Barley flour 22_5	0.26	<LOD
Barley flour 746_6	0.30	<LOD
Barley flour 568_7	0.26	<LOD
Barley flour 860_8	0.26	<LOD
Barley flour 636_9	0.42	LOD < X < LOQ
Barley flour 703_10	0.00	<LOD
Brewed B.T. 49_1	0.61	LOD < X < LOQ
Brewed B.T. 45_2	0.53	LOD < X < LOQ
Brewed B.T. 66_3	0.57	LOD < X < LOQ
Brewed B.T. 2_4	0.68	LOD < X < LOQ
Brewed B.T. 22_5	0.40	LOD < X < LOQ
Brewed B.T. 746_6	0.75	LOD < X < LOQ
Brewed B.T. 568_7	0.40	LOD < X < LOQ
Brewed B.T. 860_8	0.70	LOD < X < LOQ
Brewed B.T. 636_9	0.63	LOD < X < LOQ
Potatoes 49_1	0.00	<LOD
Potatoes 45_2	0.00	<LOD
Potatoes 66_3 b	0.25	<LOD
Potatoes 22_5	0.00	<LOD
Potatoes 746_6	0.74	LOD < X < LOQ
Potatoes 568_7	0.27	<LOD
Potatoes 860_8	0.40	LOD < X < LOQ
Potatoes 636_9	0.01	<LOD
Potatoes 703_10	0.40	LOD < X < LOQ
Wheat 49_1	0.00	<LOD
Wheat 45_2	0.33	LOD < X < LOQ
Wheat 66_3	0.81	LOD < X < LOQ
Wheat 2_4	0.53	LOD < X < LOQ
Wheat 22_5	0.67	LOD < X < LOQ
Wheat 746_6	0.42	LOD < X < LOQ
Wheat 568_7	0	<LOD
Wheat 860_8	0.66	LOD < X < LOQ
Wheat 636_9	2.53	
Wheat 703_10	0	<LOD
Rice 49_1	0.53	LOD < X < LOQ
Rice 568_7	0.91	LOD < X < LOQ
Cabbage (18)	0.21	<LOD
Noodles B	1.06	

Table 6 Brewed Black tea mineral content (mg/l).

	mg/l of brewed black tea (10gMF/100ml)	Ca	P	Mg	Fe	Zn	Mn	Sr	Mo
	Brewed Blank 01/06	1.63	0.00	1.40	0.56	0.04	0.09	0.38	0.25
	Brewed Blank 02/06	1.00	0.00	0.15	0.44	0.01	0.06	0.44	0.25
Samples of January	Brewed B.T. 49_1	26.7	21.1	48.5	<1.4	0.32	30.0	<1	<0.5
	Brewed B.T. 45_2	40.6	19.0	7.6	<1.4	0.49	39.2	<1	<0.5
	Brewed B.T. 66_3	40.3	16.3	8.3	3.08	0.42	43.9	<1	<0.5
	Brewed B.T. 2_4	25.4	16.2	36.0	<1.4	0.26	21.1	<1	<0.5
	Brewed B.T. 22_5	44.3	23.6	77.3	<1.4	0.51	43.6	<1	<0.5
	Brewed B.T. 746_6	43.8	20.9	69.2	<1.4	0.50	39.1	<1	<0.5
	Brewed B.T. 568_7	23.8	21.2	64.9	1.75	0.50	30.2	<1	<0.5
	Brewed B.T. 860_8	31.0	19.8	62.5	<1.4	0.32	29.1	<1	<0.5
	Brewed B.T. 636_9	33.5	14.5	52.2	1.52	0.32	33.8	<1	<0.5
	Brewed B.T. 703_10	32.4	25.8	64.5	<1.4	0.34	34.8	<1	<0.5
Samples of May	Brewed B.T. 49_1	32.2	18.6	48.6	1.63	0.30	29.2	<1	<0.5
	Brewed B.T. 45_2	35.6	15.4	75.5	<1.4	0.33	34.7	<1	<0.5
	Brewed B.T. 66_3	32.1	18.7	56.5	<1.4	0.31	31.5	<1	<0.5
	Brewed B.T. 2_4	28.6	18.8	40.6	<1.4	0.26	27.2	<1	<0.5
	Brewed B.T. 22_5	35.3	16.7	57.1	1.46	0.30	38.3	<1	<0.5
	Brewed B.T. 746_6	39.7	19.5	64.8	1.65	0.30	31.5	<1	<0.5
	Brewed B.T. 568_7	40.2	24.3	68.9	<1.4	0.32	32.9	<1	<0.5
	Brewed B.T. 860_8	29.4	16.9	57.6	1.41	0.28	20.9	<1	<0.5
	Brewed B.T. 636_9	33.7	13.5	47.7	<1.4	0.33	22.5	<1	<0.5

Table 7 Brewed Black tea mineral content ($\mu\text{g/l}$).

	$\mu\text{g/l}$ of brewed black tea (10gMF/100ml)	Cu	Ni	As	Cd
	Brewed Blank 01/06	9.55	284	0.26	2.0
	Brewed Blank 02/06	10.15	195	-0.03	0.9
Samples of January	Brewed B.T. 49_1	95.8	845	10.7	<10
	Brewed B.T. 45_2	107.1	895	16.3	<10
	Brewed B.T. 66_3	214.5	772	15.4	<10
	Brewed B.T. 2_4	83.4	392	25.2	<10
	Brewed B.T. 22_5	72.5	1171	12.3	<10
	Brewed B.T. 746_6	97.7	524	16.6	<10
	Brewed B.T. 568_7	147.8	510	11.9	<10
	Brewed B.T. 860_8	58.1	608	17.3	<10
	Brewed B.T. 636_9	32.6	462	12.6	<10
	Brewed B.T. 703_10	29.5	706	10.9	<10
Samples of May	Brewed B.T. 49_1	51.9	776	21.4	<10
	Brewed B.T. 45_2	63.2	882	17.5	<10
	Brewed B.T. 66_3	57.0	808	16.3	<10
	Brewed B.T. 2_4	83.0	645	21.4	<10
	Brewed B.T. 22_5	34.4	691	12.1	<10
	Brewed B.T. 746_6	28.5	579	19.3	<10
	Brewed B.T. 568_7	40.0	741	13.4	<10
	Brewed B.T. 860_8	65.7	673	21.3	<10
	Brewed B.T. 636_9	53.0	733	16.6	<10

Table 8 Evaluation of daily intakes.

Child		P (mg/d)			Ca (mg/d)		
		min.	av.	max.	min.	av.	max.
1_49	January	152	176	200	51	60	69
	% of RDA	30	35	40	6	8	9
	Mai	969	1163	1360	101	121	142
	% of RDA	194	233	272	13	15	18
2_45	January	986	1071	1155	98	125	152
	% of RDA	197	214	231	12	16	19
	Mai	1442	1766	2095	176	206	239
	% of RDA	288	353	419	22	26	30
3_66	January	462	512	561	49	67	82
	% of RDA	100	111	122	10	13	16
	Mai	466	537	663	45	54	65
	% of RDA	101	117	144	9	11	13
4_2	January	662	725	788	63	81	99
	% of RDA	144	158	171	13	16	20
	Mai	982	1209	1439	121	144	170
	% of RDA	214	263	313	24	29	34
5_22	January	1393	1508	1624	121	158	193
	% of RDA	279	302	325	15	20	24
	Mai	912	1105	1301	104	122	142
	% of RDA	182	221	260	13	15	18
6_746	January	762	840	919	70	92	112
	% of RDA	166	183	200	14	18	22
	Mai	432	522	612	48	57	66
	% of RDA	94	113	133	10	11	13
7_568	January	1060	1165	1270	120	156	190
	% of RDA	230	253	276	24	31	38
	Mai	91	128	165	33	36	40
	% of RDA	20	28	36	7	7	8
8_860	January	836	919	1001	78	105	129
	% of RDA	167	184	200	10	13	16
	Mai	1014	1239	1468	129	150	174
	% of RDA	203	248	294	16	19	22
9_636	January	443	487	532	54	68	81
	% of RDA	89	97	106	7	8	10
	Mai	367	447	528	47	55	64
	% of RDA	73	89	106	6	7	8
10_703	January	549	594	639	54	68	82
	% of RDA	110	119	128	7	9	10
	Mai	342	419	496	74	79	85
	% of RDA	68	84	99	9	10	11

Table 9 Evaluation of daily intakes.

Child		Mg (mg/d)			Fe (mg/d)		
		min.	av.	max.	min.	av.	max.
1_49	January	25	38	49	1.2	4.7	8.1
	% of RDA	20	29	38	12	47	81
	May	201	327	452	22.8	40.6	58.3
	% of RDA	155	252	348	228	406	583
2_45	January	259	314	365	18.8	31.4	43.9
	% of RDA	199	241	281	188	314	439
	May	292	494	695	35	62.3	89.6
	% of RDA	225	380	534	350	623	896
3_66	January	120	152	182	8.8	15	21.3
	% of RDA	150	190	227	126	214	304
	May	95	161	226	11.5	20.3	29.1
	% of RDA	119	201	283	164	290	416
4_2	January	166	205	242	11.2	19.2	27.2
	% of RDA	207	256	302	160	274	389
	May	235	359	485	22.5	42.9	63.4
	% of RDA	294	449	606	321	613	906
5_22	January	365	440	509	26.5	44.7	62.7
	% of RDA	281	338	392	265	447	627
	May	182	304	425	21.5	38.1	54.7
	% of RDA	140	234	327	215	381	547
6_746	January	192	241	288	12.9	20.9	28.8
	% of RDA	240	302	360	184	299	411
	May	88	148	208	10.7	18.7	26.7
	% of RDA	110	185	260	153	267	381
7_568	January	268	334	394	19.1	34.1	49.1
	% of RDA	335	417	492	273	487	701
	May	29	40	51	1.8	4.3	6.9
	% of RDA	37	50	64	26	61	99
8_860	January	219	241	323	15.8	25.7	35.6
	% of RDA	169	186	248	158	257	356
	May	214	343	491	23.1	42.2	61.2
	% of RDA	165	264	378	231	422	612
9_636	January	106	133	157	7	13	19
	% of RDA	82	102	121	70	130	190
	May	82	125	168	8	15	22
	% of RDA	63	96	129	80	150	220
10_703	January	143	172	199	10.3	17.4	24.4
	% of RDA	110	132	153	103	174	244
	May	58	88	117	6	10.7	15.4
	% of RDA	45	68	90	60	107	154

Table 10 Evaluation of daily intakes.

Child		Zn (mg/d)			Cu (mg/d)		
		min.	av.	max.	min.	av.	max.
1_49	January	0.77	1.03	1.3	0.208	0.258	0.302
	% of RDA	15	21	26	47	59	69
	May	6.19	7.32	8.47	0.895	1.14	1.36
	% of RDA	124	146	169	203	259	309
2_45	January	4.85	6.14	7.44	0.913	1.128	1.331
	% of RDA	97	123	149	208	256	303
	May	8.38	10.26	12.16	1.304	1.658	2.004
	% of RDA	168	205	243	296	377	455
3_66	January	2.2	2.82	3.45	0.45	0.577	0.699
	% of RDA	73	94	115	132	170	206
	May	2.7	3.23	3.75	0.406	0.507	0.608
	% of RDA	90	108	125	119	149	179
4_2	January	3.94	4.9	5.86	0.698	0.886	1.067
	% of RDA	131	163	195	205	261	314
	May	6.36	7.66	8.91	0.955	1.277	1.575
	% of RDA	212	255	297	281	376	463
5_22	January	6.96	8.84	10.7	1.299	1.584	1.86
	% of RDA	139	177	214	295	360	423
	May	5.7	6.86	8.01	0.848	1.082	1.336
	% of RDA	114	137	160	193	246	304
6_746	January	4.77	5.86	6.97	0.824	1.082	1.336
	% of RDA	159	195	232	242	318	393
	May	2.49	2.98	3.45	0.374	0.465	0.558
	% of RDA	83	99	115	110	137	164
7_568	January	5.22	6.68	8.15	1.048	1.306	1.553
	% of RDA	174	223	272	308	384	457
	May	0.56	0.807	1.08	0.114	0.175	0.231
	% of RDA	19	27	36	34	51	68
8_860	January	4.3	5.46	6.6	0.812	1.046	1.274
	% of RDA	86	109	132	185	238	290
	May	6.72	8.13	9.55	1.004	1.318	1.663
	% of RDA	134	163	191	228	300	378
9_636	January	2.57	3.23	3.88	0.482	0.604	0.723
	% of RDA	51	65	78	110	137	164
	May	2.64	3.15	3.72	0.383	0.512	0.687
	% of RDA	53	63	74	87	116	156
10_703	January	2.74	3.46	4.18	0.509	0.621	0.728
	% of RDA	55	69	84	116	141	165
	May	3.17	3.9	4.71	0.458	0.632	0.849
	% of RDA	63	78	94	104	144	193

Table 11 Evaluation of daily intakes.

Child		Mn (mg/d)			Se (µg/d)		
		min.	av.	max.	min.	av.	max.
1_49	January	1.5	1.8	2	2.1	6.5	12.8
	% of RDA	100	120	133	7	22	43
	May	6.2	7.1	7.8	9.7	29.5	59.1
	% of RDA	413	473	520	32	98	197
2_45	January	4.8	5.8	7	4.8	14.6	28.9
	% of RDA	320	387	467	16	49	96
	May	8.2	9.4	10.6	8.6	25.9	51.8
	% of RDA	547	627	707	29	86	173
3_66	January	2.3	2.8	3.3	2.8	8.5	16.9
	% of RDA	192	233	275	14	43	85
	May	2.6	2.9	3.2	2.4	7.4	14.8
	% of RDA	217	242	267	12	37	74
4_2	January	4	4.8	5.7	7.7	23.3	46.5
	% of RDA	333	400	475	39	117	233
	May	6.1	7.2	7.8	10.7	32.4	64.7
	% of RDA	508	600	650	54	162	324
5_22	January	5.9	7.2	8.6	6.7	20.4	40.6
	% of RDA	393	480	573	22	68	135
	May	5.6	6.4	7.1	8.5	25.8	51.5
	% of RDA	373	427	473	28	86	172
6_746	January	4.2	5.1	6	11.1	33.6	67.1
	% of RDA	350	425	500	56	168	336
	May	2.5	2.8	3.1	2.2	6.8	13.6
	% of RDA	208	233	258	11	34	68
7_568	January	4.8	5.8	6.9	6.5	19.7	39.3
	% of RDA	400	483	575	33	99	197
	May	0.9	1.2	1.4	1.1	3.4	6.8
	% of RDA	75	100	117	6	17	34
8_860	January	3.7	4.6	5.4	6.6	19.9	39.9
	% of RDA	247	307	360	22	66	133
	May	6.4	7.4	8.3	12.6	38.2	76.4
	% of RDA	427	493	553	42	127	255
9_636	January	2.5	2.9	3.5	5.1	15.4	30.7
	% of RDA	167	193	233	17	51	102
	May	2.6	3.1	3.5	6.2	18.7	37.5
	% of RDA	173	207	233	21	62	125
10_703	January	2.3	2.9	3.4	2.6	7.9	15.9
	% of RDA	153	193	227	9	26	53
	May	3.1	3.6	4.1	12.3	37.3	74.6
	% of RDA	207	240	273	41	124	249

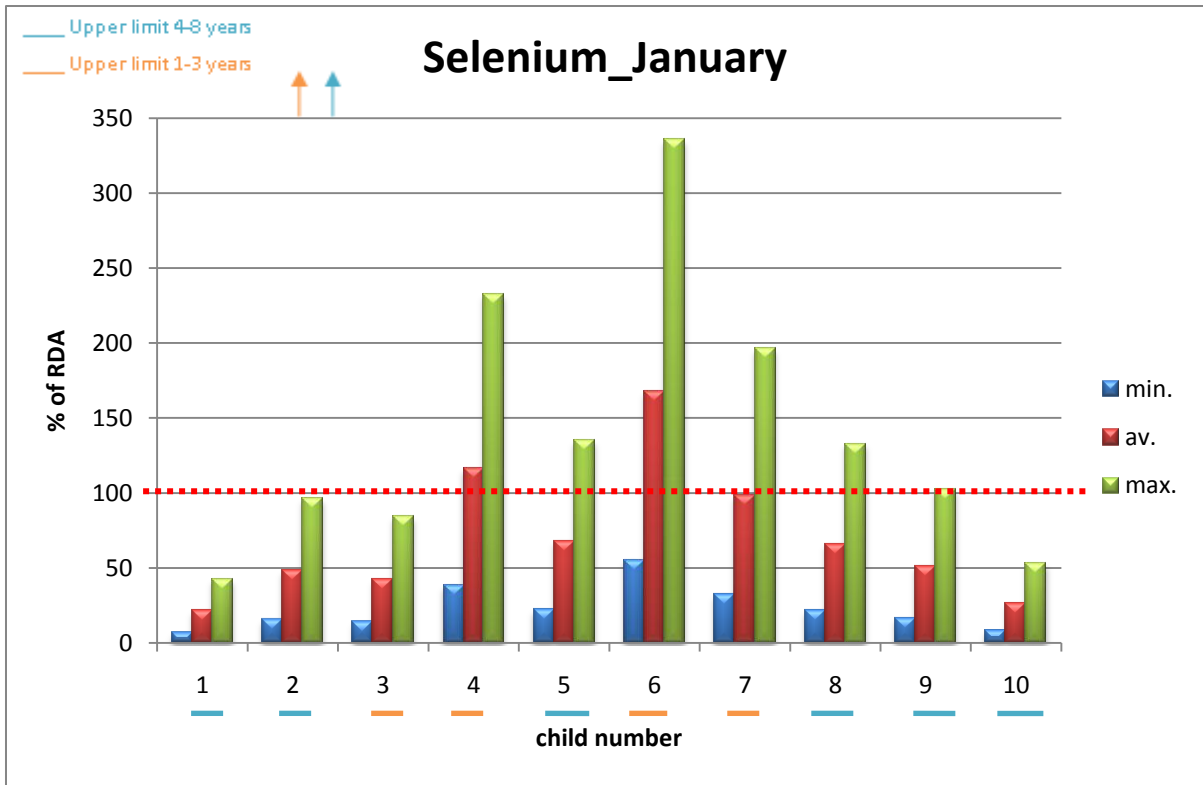

Graph 15 Approximation of selenium daily intake by child, expressed in % of RDA. Numbers underlined belong to life stage group: 1-3 years in orange, 4-8 years in blue, red dotted line valid for both.

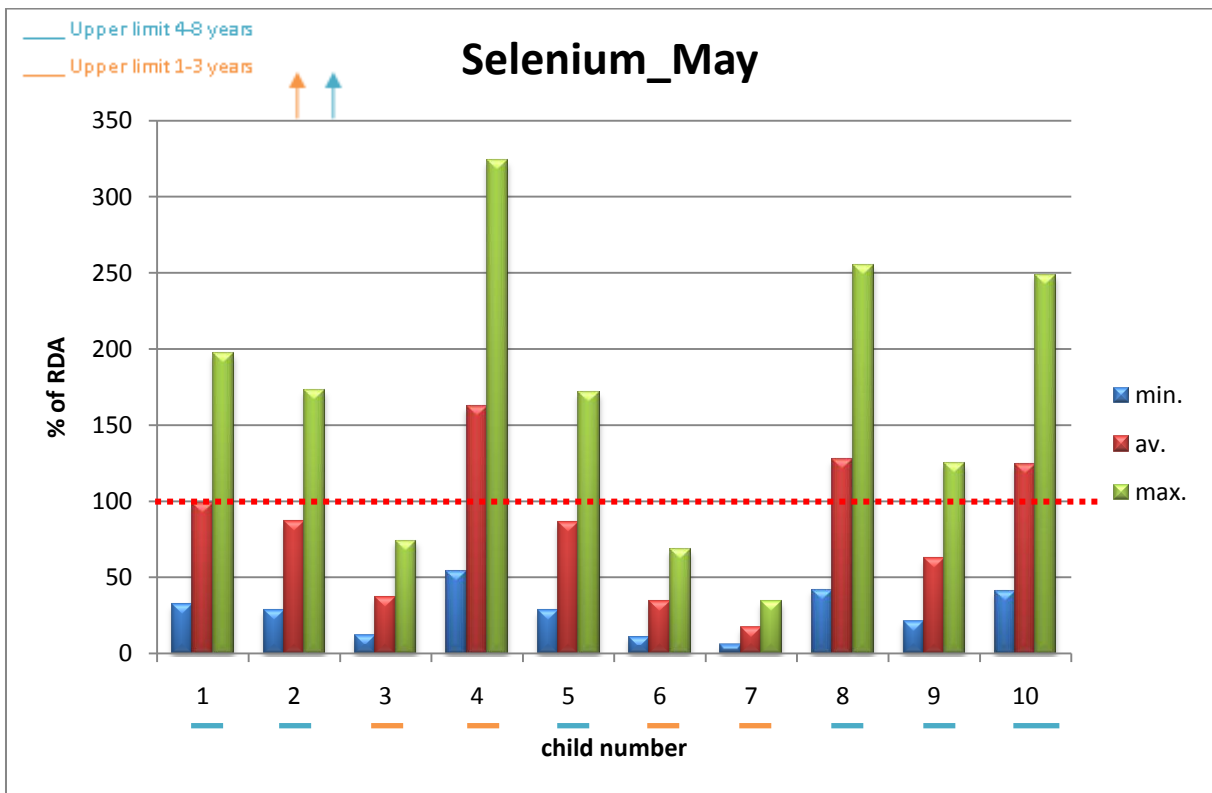

Graph 16 Approximation of selenium daily intake by child, expressed in % of RDA. Numbers underlined belong to life stage group: 1-3 years in orange, 4-8 years in blue, red dotted line valid for both.